



# Disconnectors and earthing switches

For applications from 72.5 kV to 420 kV



# Table of Contents

SERW	4
Quality through R&D	5
HV AIS Substation Design	6
Horizontal disconnectors	7
Pantograph disconnectors	14
Vertical disconnectors	19
Earthing switches	23
Motor drives	29
Motor drive mounting options	33
Services	34
SERW as a company of R&S	35

# SERW

## Your partner for reliable disconnectors

Modern power transmission in high-voltage networks must meet the highest reliability standards to ensure a continuous power supply.

Our wealth of experience in manufacturing high-voltage disconnectors and earthing switches ensures we can support our customers as a competent and reliable partner. All of our switchgear is precisely tailored to meet customer requirements, while taking a wide range of criteria into consideration.

As an expert partner, we support our customers at every step of the process – from planning and supply of the switchgear to installation and commissioning, as well as after-sales services.

The name SERW stands for reliability and quality in the market. Modern production processes and lean manufacturing

methods, highly-qualified personnel as well as an integrated management system all guarantee our ongoing success.

### The right product for every application

Our portfolio of high-voltage switches includes disconnectors and earthing switches for nominal voltages ranging from 72.5 kV up to 420 kV. Our high-quality and reliable products are available in several different models:

- Horizontal
- Pantograph
- Vertical



Modern and durable switches are our speciality

# Quality through R&D

## R&D as the key to success

We focus on your requests to find a harmonious solution.

### Our quality

At SERW, we strongly believe that, as pioneers of new technologies, we can offer our customers innovative and high-quality products which meet the respective requirements of diverse projects. All of our products incorporate state-of-the-art technologies on the basis of the highest quality standards.

### Focus on R&D

SERW places a strong emphasis on R&D, which is deeply anchored in our organization. Many years of experience coupled with intensive collaboration with utility companies have helped us develop our products so that they meet – and often exceed – the requirements. This was the only way we

were able to become one of Europe's market-leading manufacturers, setting new standards along the way that are now universally established.

### Our innovations

The large number of innovations contained in our products provides the basis for their high quality, extraordinarily long service life and high efficiency.



High-voltage switches installed in a substation

# HV AIS Substation Design

## Single Line Diagram

Disconnecter switches are used in air insulated substations to provide isolation of powered equipment from the network. Disconnecters are suitable for switching small currents or where no significant change in voltage occurs across the

terminals. Thus, disconnectors provide a visual separation of two different networks.

The sketch below illustrates how disconnectors are used in a 420kV substation, for example.

420kV/50Hz,  $I_r=4000A$ ,  $I_k=63kA/1S$

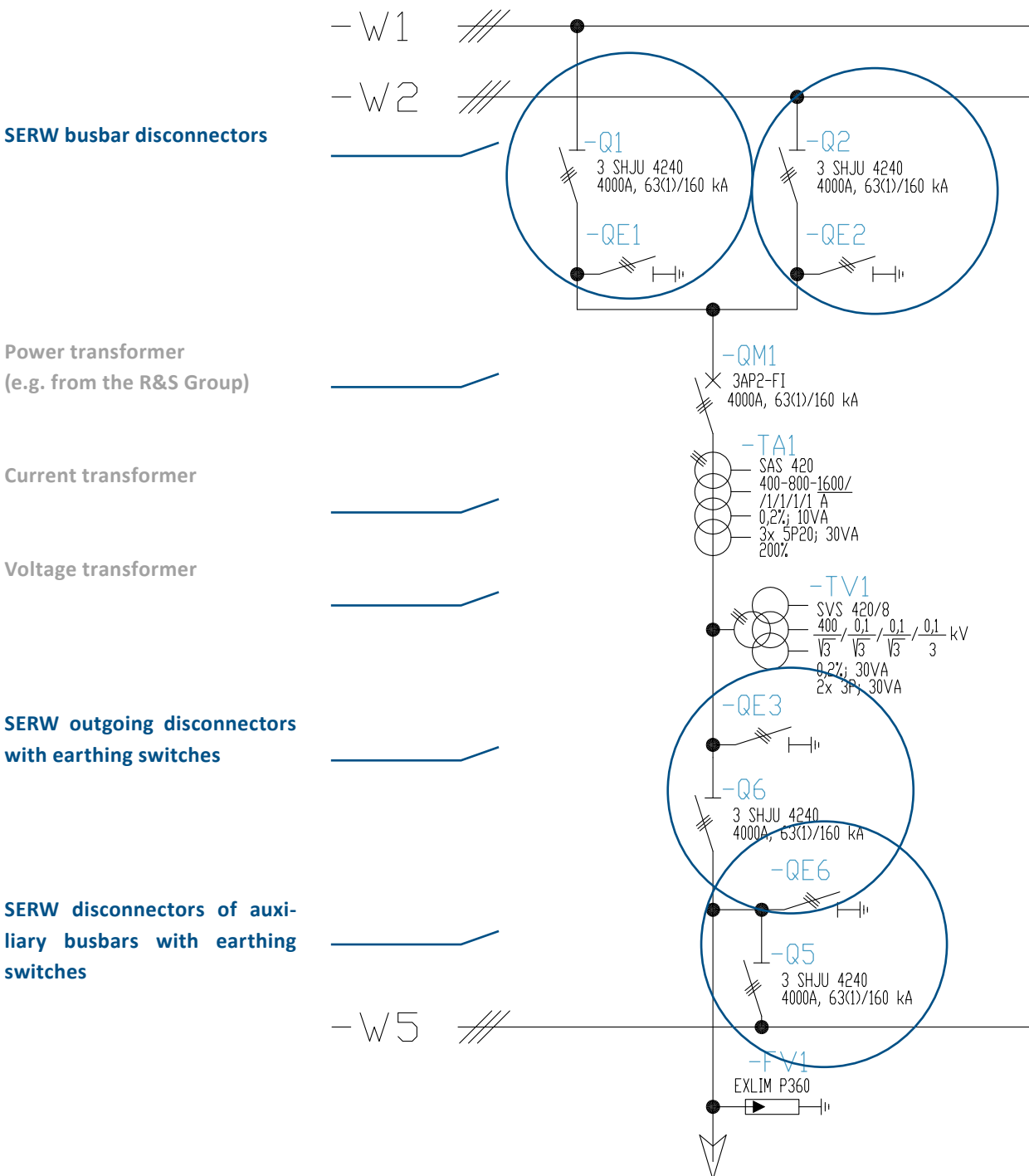

Illustration of an open-air 420kV substation using disconnectors and earthing switches

# Horizontal disconnectors

72.5 kV - 420 kV

## Features

- Stable opening and closing thanks to a technologically sophisticated design
- Maintenance-free contact system
- Mounted on a durable steel frame with a long service life
- High mechanical resistance against seismic or electrodynamic forces
- High reliability even under the most challenging environmental conditions
- Straightforward coupling of the drives with the disconnectors and earthing switches
- High corrosion protection



Three-pin, horizontal disconnecter 123 kV at a substation in Hofheim

# 72.5 kV – 145 kV type 3SHT up to 4000 A, 63 kA/160 kA

## Technical data

Rated voltage	72.5 kV	123 kV	145 kV
Rated current	Up to 4000 A		
Rated short-circuit current	Up to 63 kA (1s)		
Rated peak withstand current	Up to 160 kA		
Power frequency withstand voltage AC Hz, 1 min – against ground	140 kV	230 kV	275 kV
Power frequency withstand voltage AC 50 Hz, 1 min – across isolating distance	160 kV	265 kV	315 kV
Rated lightning impulse withstand voltage 1.2/50 $\mu$ s – against ground	325 kV	550 kV	650 kV
Rated lightning impulse withstand voltage 1.2/50 $\mu$ s – across isolating distance	375 kV	630 kV	750 kV



Horizontal disconnector 123 kV

# 72.5 kV – 145 kV type 3SHT up to 4000 A, 63 kA/160 kA

Side-by-side-installation

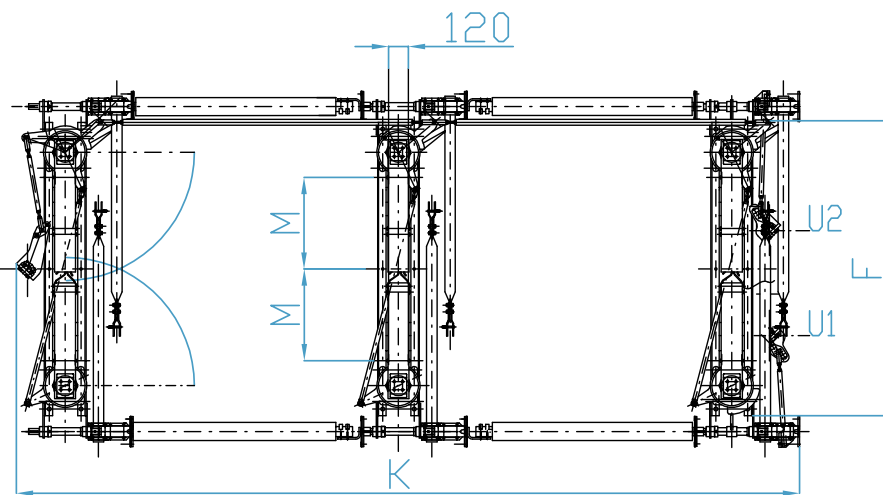
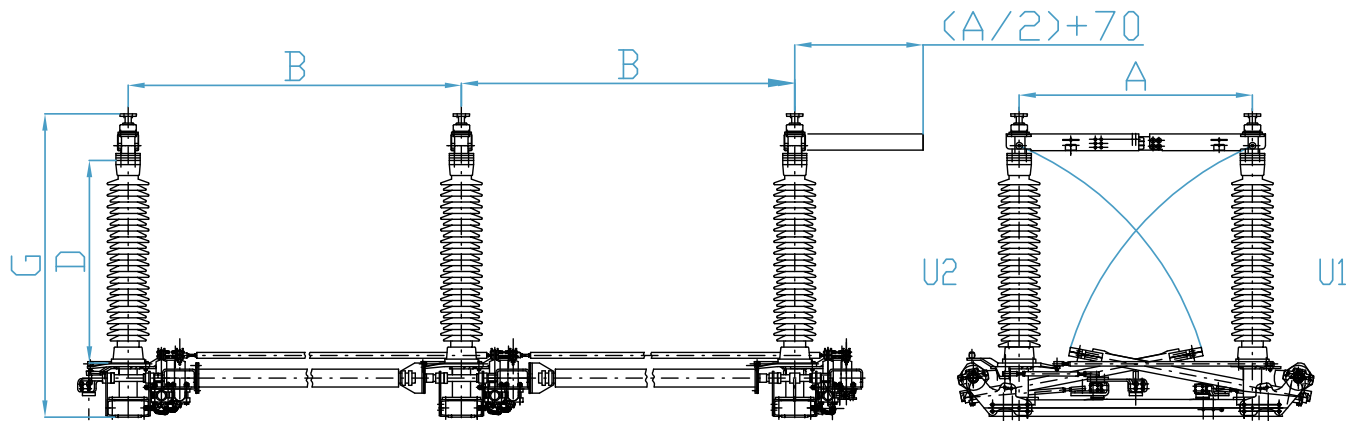

## Dimensions

	A	B	D	G	F	K	M
Ur = 72.5kV	940	1400	770	1345	1300	3630	400
Ur = 123 kV	1400	2000	1215	1789/1820	1760	4860	550
Ur = 145 kV	1700	2300	1500	2030	2060	5460	550

# 72.5 kV – 145 kV type 3SHT up to 4000 A, 63 kA/160 kA

Installation with one behind the other

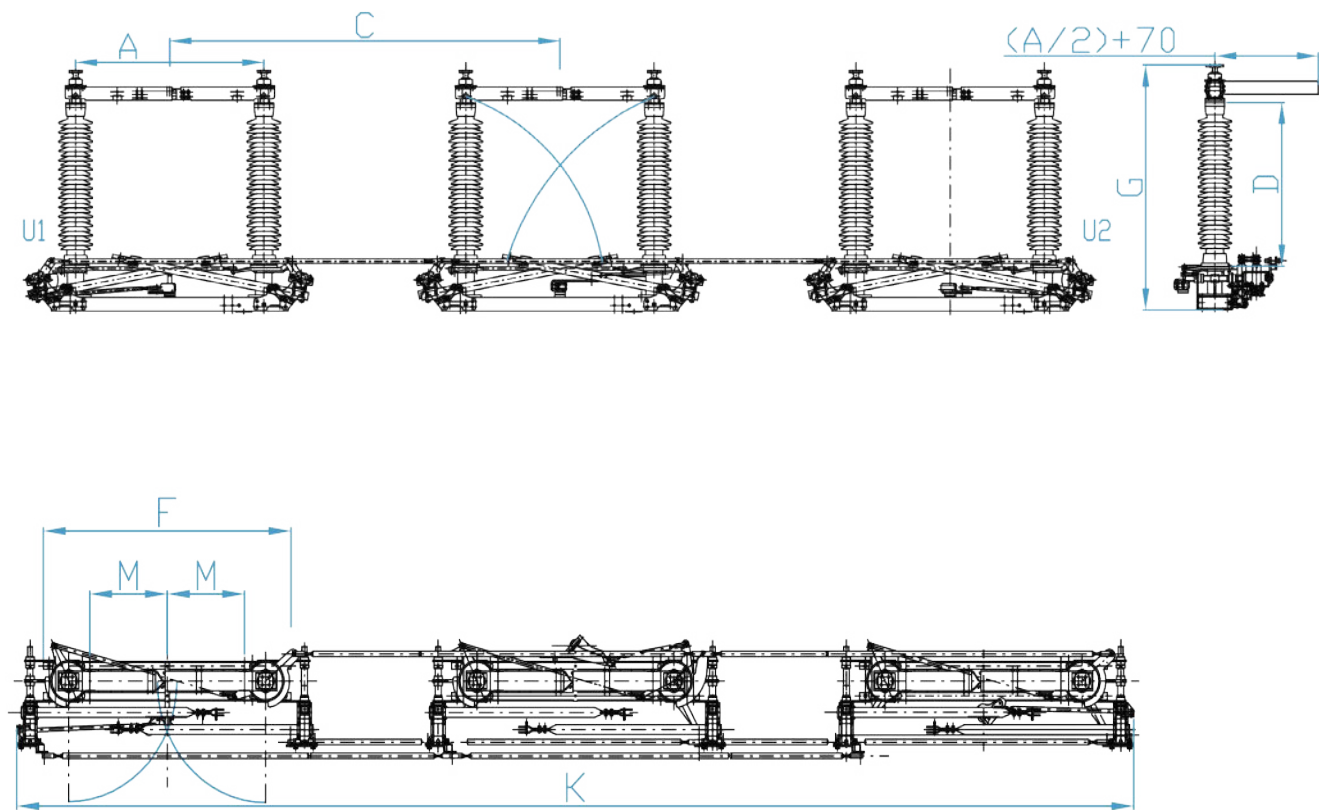

## Dimensions

	A	C	D	G	F	K	M
Ur = 72.5 kV	940	1900	770	1345	1300	3580	400
Ur = 123 kV	1400	2800	1215	1789/1820	1760	7740	550
Ur = 145 kV	1700	3400	1500	2030	2100	9240	550

# 245 kV type 1SHJ up to 3150 A, 50 kA/125 kA

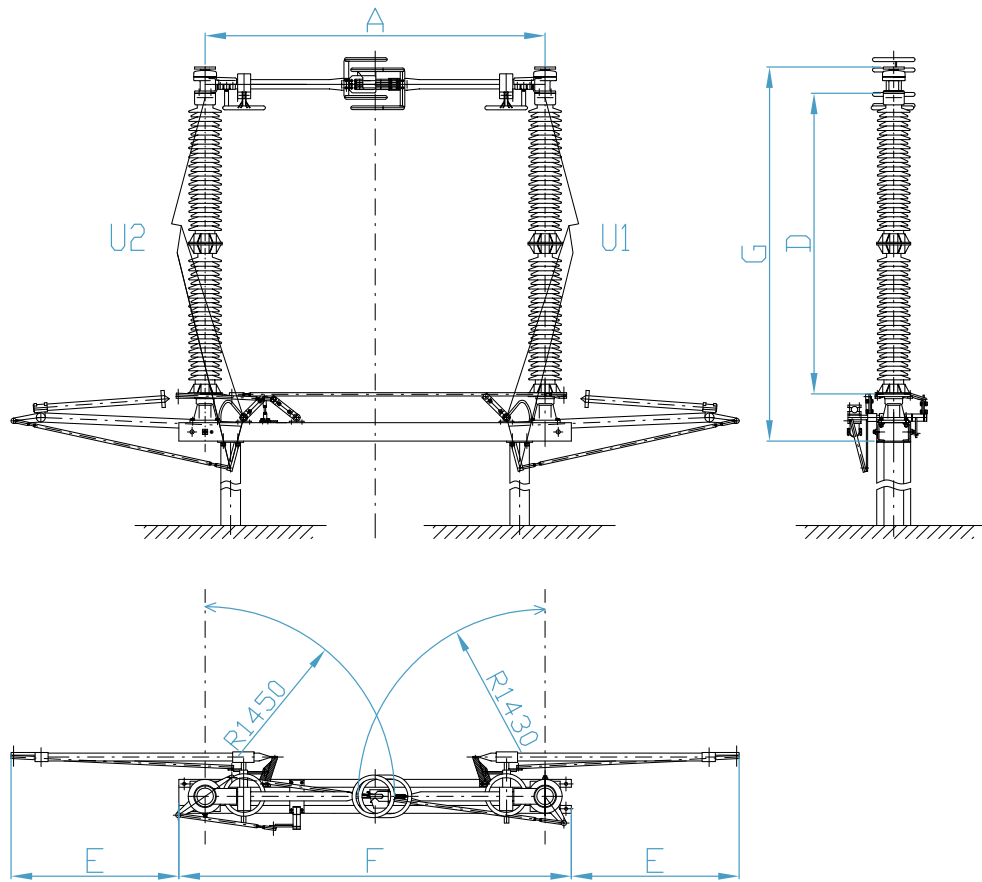

## Dimensions

$I_r$ , 2000 A, 3150 A	A	D	E	F	G
	2600	2300	1300	3000	2860

## Technical data

Rated voltage	245 kV
Rated current	Up to 3150 A
Rated short-circuit current	Up to 50 kA (1s)
Rated peak withstand current	Up to 125 kA
Power frequency withstand voltage AC 50 Hz, 1 min – against ground	460 kV
Power frequency withstand voltage AC 50 Hz, 1 min – across isolating distance	530 kV
Rated lightning impulse withstand voltage 1.2/50 $\mu$ s – against ground	1050 kV
Rated lightning impulse withstand voltage 1.2/50 $\mu$ s – across isolating distance	1200 kV

# 420 kV type 1SHJ up to 3150 A, 50 kA/125 kA

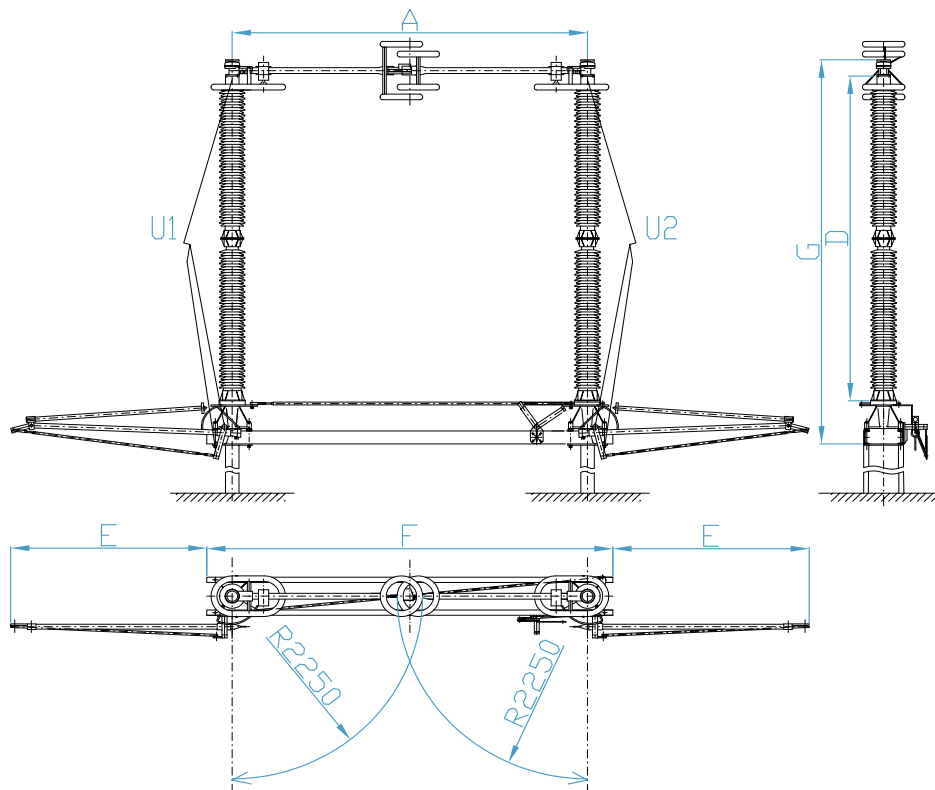

## Dimensions

	A	D	E	F	G
I <sub>r</sub> , 2000 A, 31500 A	4200	4000	2320	4800	4730
	4200	3650	2120	4800	4380
	4200	3350	1960	4800	4080

## Technical data

Rated voltage	420 kV
Rated current	Up to 3150 A
Rated short-circuit current	Up to 50 kA (1s)
Rated peak withstand current	Up to 125 kA
Power frequency withstand voltage AC 50 Hz, 1 min – against ground	520 kV
Power frequency withstand voltage AC 50 Hz, 1 min – across isolating distance	610 kV
Rated lightning impulse withstand voltage 1.2/50 μs – against ground	1425 kV
Rated lightning impulse withstand voltage 1.2/50 μs – across isolating distance	1425 (+240) kV

# 420 kV type 3SHJ up to 4000 A, 63 kA/160 kA

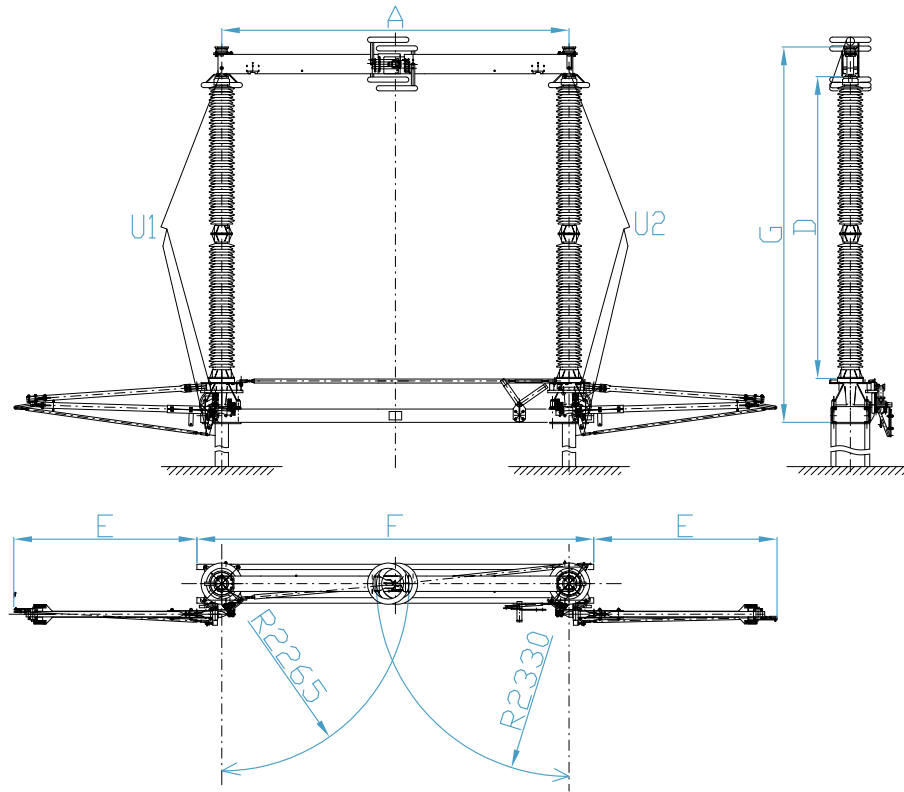

## Dimensions

$I_r$ , 4000 A	Isolator	A	D	E	F	G
	Up = 1550 kV	4200	3350	2060	4800	4240
	Up = 1675 kV	4200	3650	2220	4800	4540
	Up = 1800 kV	4200	4000	2420	4800	4890

## Technical data

Rated voltage	420 kV
Rated current	Up to 4000 A
Rated short-circuit current	Up to 63 kA (1s)
Rated peak withstand current	Up to 160 kA
Power frequency withstand voltage AC 50 Hz, 1 min – against ground	520 kV
Power frequency withstand voltage AC 50 Hz, 1 min – across isolating distance	610 kV
Rated lightning impulse withstand voltage 1.2/50 $\mu$ s – against ground	1425 kV
Rated lightning impulse withstand voltage 1.2/50 $\mu$ s – across isolating distance	1425 (+240) kV

# Pantograph disconnectors

123 kV - 420 kV

## Features

- Stable opening and closing thanks to a technologically sophisticated design
- Maintenance-free contact system
- Reduced space requirement (diagonal arrangement)
- Mounted on a durable steel frame with a long service life
- High mechanical resistance against seismic or electrodynamic forces
- High reliability even under the most challenging environmental conditions
- Straightforward coupling of the drives with the disconnectors and earthing switches
- High corrosion protection



Pantograph Disconnector 123 kV

# 123 kV type 1SPJ up to 3150 A, 50 kA/125 kA

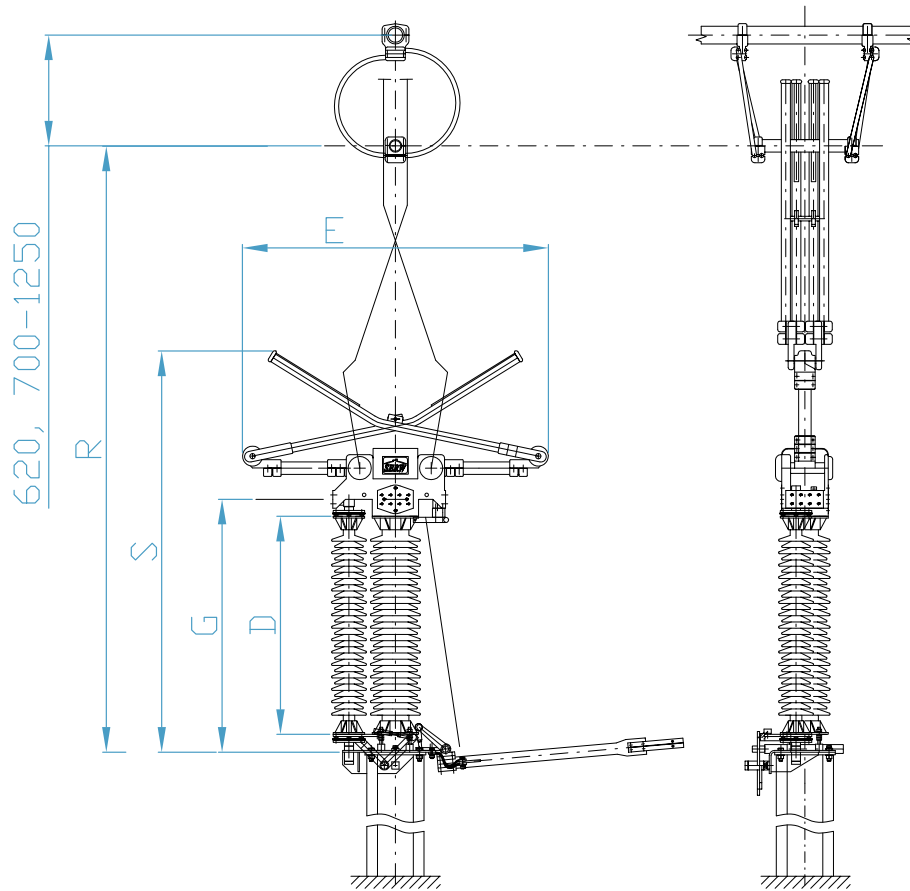

## Dimensions

Ur = 123 kV	Isolator	D	G	E	S	R
	Up = 550 kV		1220	1420	1750	2250

## Technical data

Rated voltage	123 kV
Rated current	Up to 3150 A
Rated short-circuit current	Up to 50 kA (1s)
Rated peak withstand current	Up to 125 kA
Power frequency withstand voltage AC 50 Hz, 1 min – against ground	230 kV
Power frequency withstand voltage AC 50 Hz, 1 min – across isolating distance	265 kV
Rated lightning impulse withstand voltage 1.2/50 $\mu$ s – against ground	550 kV
Rated lightning impulse withstand voltage 1.2/50 $\mu$ s – across isolating distance	630 kV

# 245 kV type 1SPJ up to 3150 A, 50 kA/125 kA

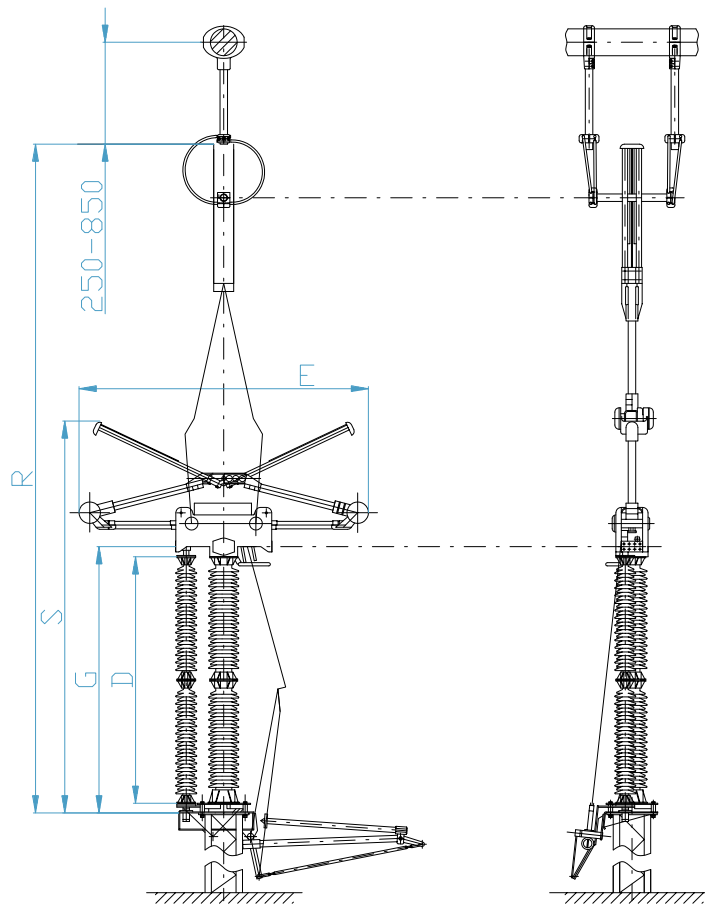

## Dimensions

Ur = 245 kV	Isolator	D	G	E	S	R
	Up = 1050 kV		2300	2500	2700	3700

## Technical data

Rated voltage	245 kV
Rated current	Up to 3150 A
Rated short-circuit current	Up to 50 kA (1s)
Rated peak withstand current	Up to 125 kA
Power frequency withstand voltage AC 50 Hz, 1 min – against ground	460 kV
Power frequency withstand voltage AC 50 Hz, 1 min – across isolating distance	530 kV
Rated lightning impulse withstand voltage 1.2/50 $\mu$ s – against ground	1050 kV
Rated lightning impulse withstand voltage 1.2/50 $\mu$ s – across isolating distance	1200 kV

# 420 kV type 1SPJ up to 3150 A, 50 kA/125 kA

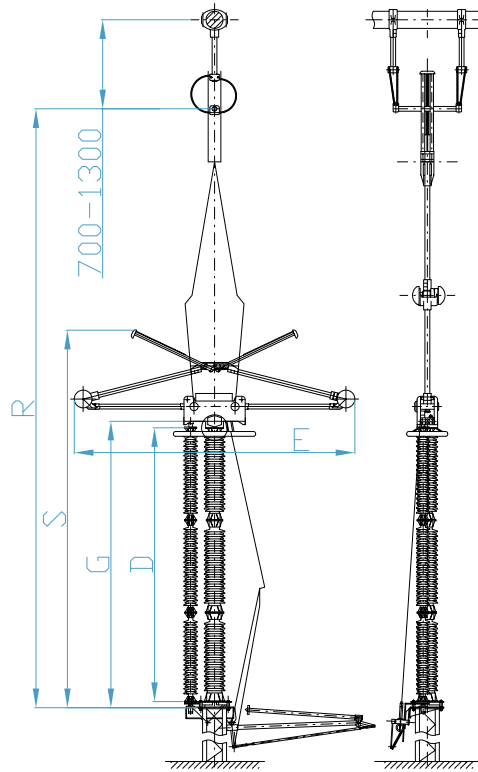

## Dimensions

Ur = 420 kV	Isolator	D	G	E	S	R
	Up = 1550 kV	3350	3550	4100	4850	8100
	Up = 1675 kV	3650	3850	4100	5150	8400
	Up = 1800 kV	4000	4200	4100	5500	8750

## Technical data

Rated voltage	420 kV
Rated current	Up to 3150 A
Rated short-circuit current	Up to 50 kA (1s)
Rated peak withstand current	Up to 125 kA
Power frequency withstand voltage AC 50 Hz, 1 min – against ground	520 kV
Power frequency withstand voltage AC 50 Hz, 1 min – across isolating distance	610 kV
Rated lightning impulse withstand voltage 1.2/50 $\mu$ s – against ground	1425 kV
Rated lightning impulse withstand voltage 1.2/50 $\mu$ s – across isolating distance	1425 (+240) kV

# 420 kV type 3SPJ up to 4000 A, 63 kA/160 kA

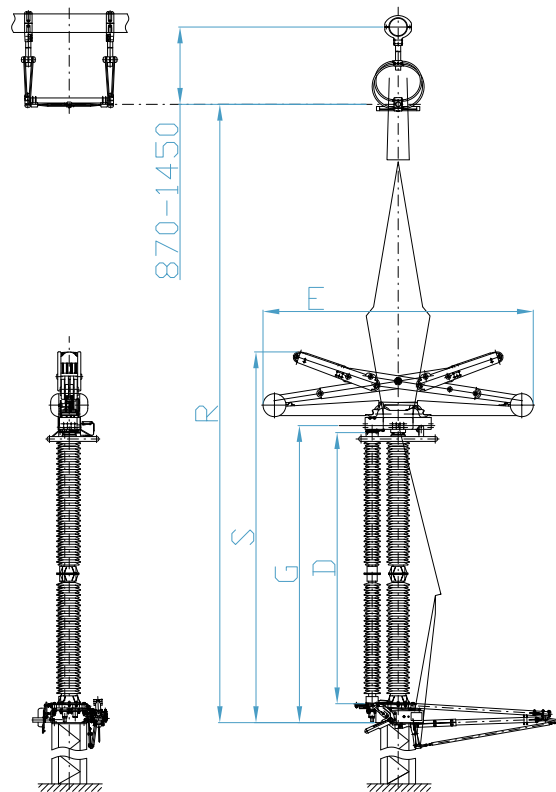

## Dimensions

Ur = 420 kV	Isolator	D	G	S	R
	Up = 1550 kV	3350	3700	4690	8450
	Up = 1675 kV	3650	4000	4990	8750
	Up = 1800 kV	4000	4350	5340	9100

## Technical data

Rated voltage	420 kV
Rated current	Up to 4000 A
Rated short-circuit current	Up to 63 kA (1s)
Rated peak withstand current	Up to 160 kA
Power frequency withstand voltage AC 50 Hz, 1 min – against ground	520 kV
Power frequency withstand voltage AC 50 Hz, 1 min – across isolating distance	610 kV
Rated lightning impulse withstand voltage 1.2/50 $\mu$ s – against ground	1425 kV
Rated lightning impulse withstand voltage 1.2/50 $\mu$ s – across isolating distance	1425 (+240) kV

# Vertical disconnectors

123 kV - 420 kV

## Features

- Stable opening and closing thanks to a technologically sophisticated design
- Maintenance-free contact system
- Mounted on a durable steel frame with a long service life
- High mechanical resistance against seismic or electrodynamic forces
- High reliability even under the most challenging environmental conditions
- Straightforward coupling of the drives with the disconnectors and earthing switches
- High corrosion protection

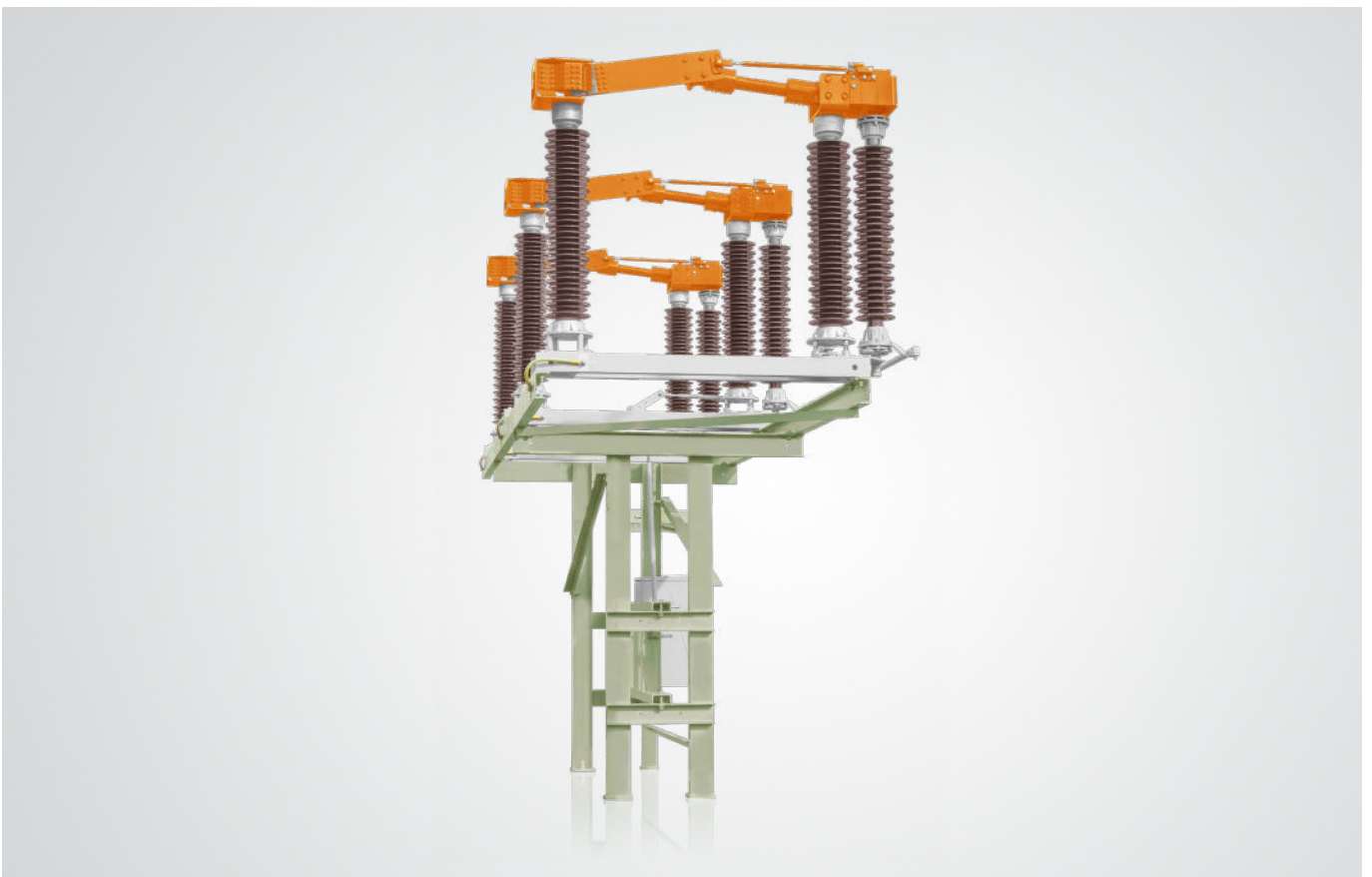

Vertical Disconnecter 123 kV

# 123 kV type 1SST up to 3150 A, 50 kA/125 kA

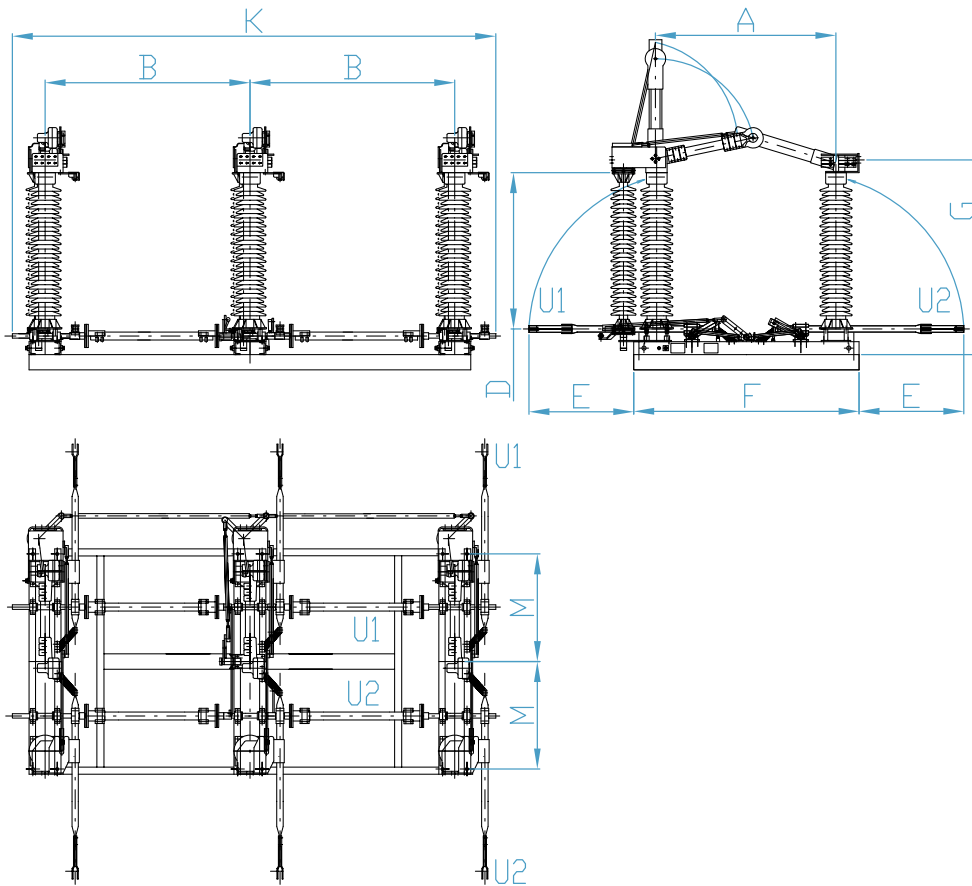

## Dimensions

Ur = 123 kV	A	B	D	G	F	E	K	M
	1400	1600	1220	1520	1760	820	3775	840

## Technical data

Rated voltage	123 kV
Rated current	Up to 3150 A
Rated short-circuit current	Up to 50 kA (1s)
Rated peak withstand current	Up to 125 kA
Power frequency withstand voltage AC 50 Hz, 1 min – against ground	230 kV
Power frequency withstand voltage AC 50 Hz, 1 min – across isolating distance	265 kV
Rated lightning impulse withstand voltage 1.2/50 $\mu$ s – against ground	550 kV
Rated lightning impulse withstand voltage 1.2/50 $\mu$ s – across isolating distance	630 kV

# 420 kV type 1SSJ up to 3150 A, 50 kA/125 kA

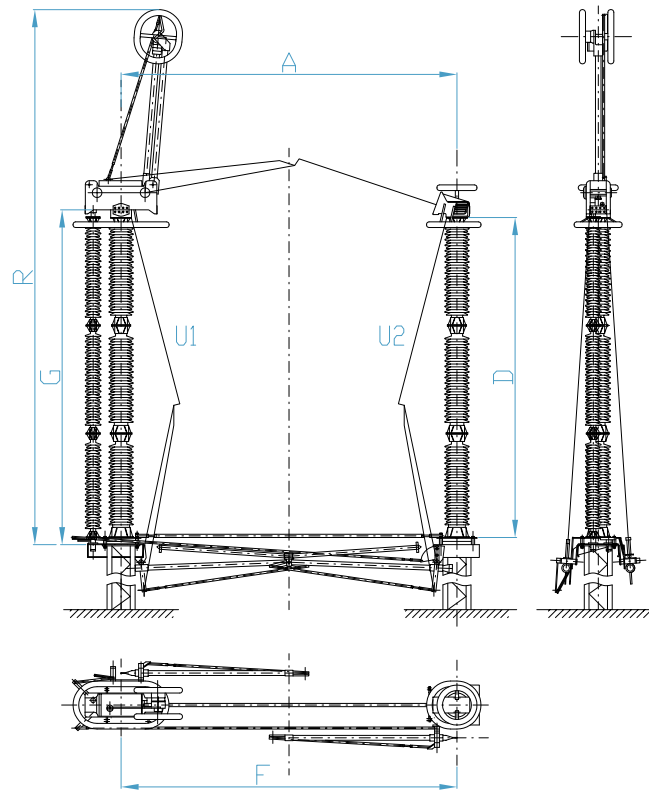

## Dimensions

Ur = 420 kV	Isolator	A	D	R	F	G
	Up = 1550 kV	4200	3350	6050	4200	3500
	Up = 1675 kV	4200	3650	6350	4200	3850
	Up = 1800 kV	4200	4000	6700	4200	4200

## Technical data

Rated voltage	420 kV
Rated current	Up to 3150 A
Rated short-circuit current	Up to 50 kA (1s)
Rated peak withstand current	Up to 125 kA
Power frequency withstand voltage AC 50 Hz, 1 min – against ground	520 kV
Power frequency withstand voltage AC 50 Hz, 1 min – across isolating distance	610 kV
Rated lightning impulse withstand voltage 1.2/50 $\mu$ s – against ground	1425 kV
Rated lightning impulse withstand voltage 1.2/50 $\mu$ s – across isolating distance	1425 (+240) kV

# 420 kV type 3SSJ up to 4000 A, 63 kA/160 kA

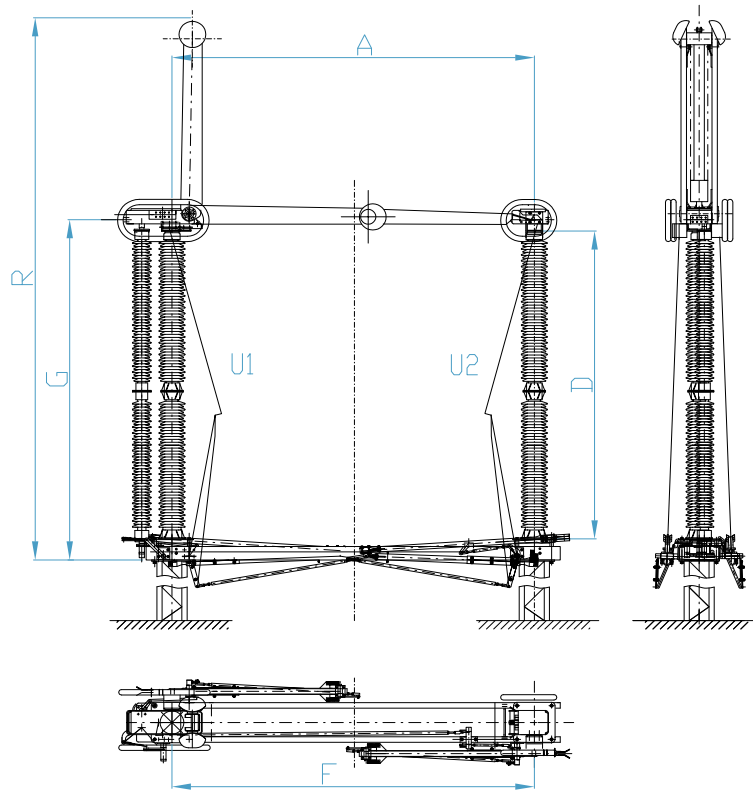

## Dimensions

Ur = 420 kV	Isolator	A	D	F	G	R
	Up = 1550 kV	4200	3350	4200	3735	6130
	Up = 1675 kV	4200	3650	4200	4035	6430
	Up = 1800 kV	4200	4000	4200	4385	6780

## Technical data

Rated voltage	420 kV
Rated current	Up to 4000 A
Rated short-circuit current	Up to 63 kA (1s)
Rated peak withstand current	Up to 160 kA
Power frequency withstand voltage AC 50 Hz, 1 min – against ground	520 kV
Power frequency withstand voltage AC 50 Hz, 1 min – across isolating distance	610 kV
Rated lightning impulse withstand voltage 1.2/50 $\mu$ s – against ground	1425 kV
Rated lightning impulse withstand voltage 1.2/50 $\mu$ s – across isolating distance	1425 (+240) kV

# Earthing switches

72.5 kV - 420 kV

## Features

- Mounted on a durable steel frame with a long service life
- High mechanical resistance against seismic or electrodynamic forces
- High reliability even under the most challenging environmental conditions
- Single and three-pin design possible
- Straightforward coupling of the drives with disconnectors and earthing switches
- High corrosion protection



Earthing switches 123 kV

# 123 kV type 1SUT up to 3150 A, 50 kA/150 kA

## Side-by-side-installation

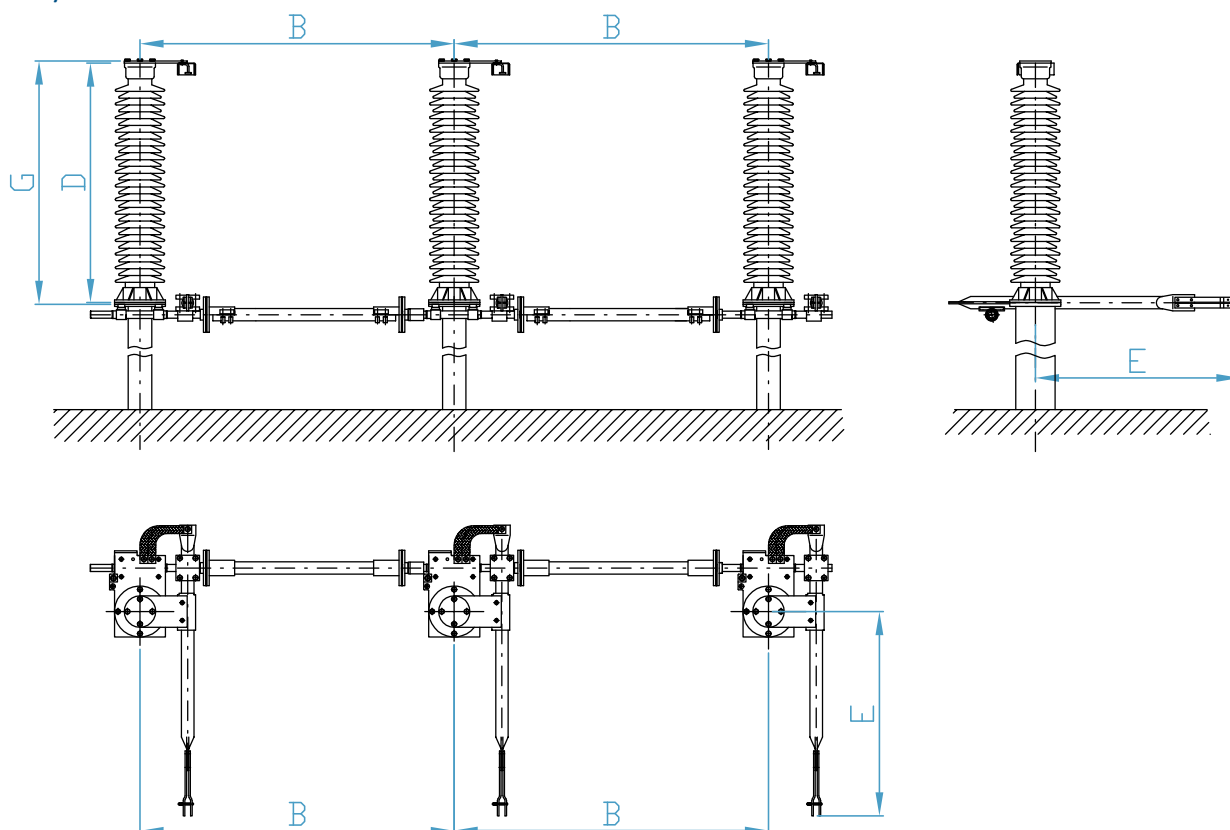

## Dimensions

Ur = 123 kV	B	D	G	E
	1600	1220	1240	1040

## Technical data

Rated voltage	123 kV
Rated current	Up to 3150 A
Rated short-circuit current	Up to 50 kA (1s)
Rated peak withstand current	Up to 125 kA
Power frequency withstand voltage AC 50 Hz, 1 min – against ground	230 kV
Power frequency withstand voltage AC 50 Hz, 1 min – across isolating distance	265 kV
Rated lightning impulse withstand voltage 1.2/50 $\mu$ s – against ground	550 kV
Rated lightning impulse withstand voltage 1.2/50 $\mu$ s – across isolating distance	630 kV

# 123 kV type 1SUT up to 3150 A, 50 kA/150 kA

Installation with one behind the other

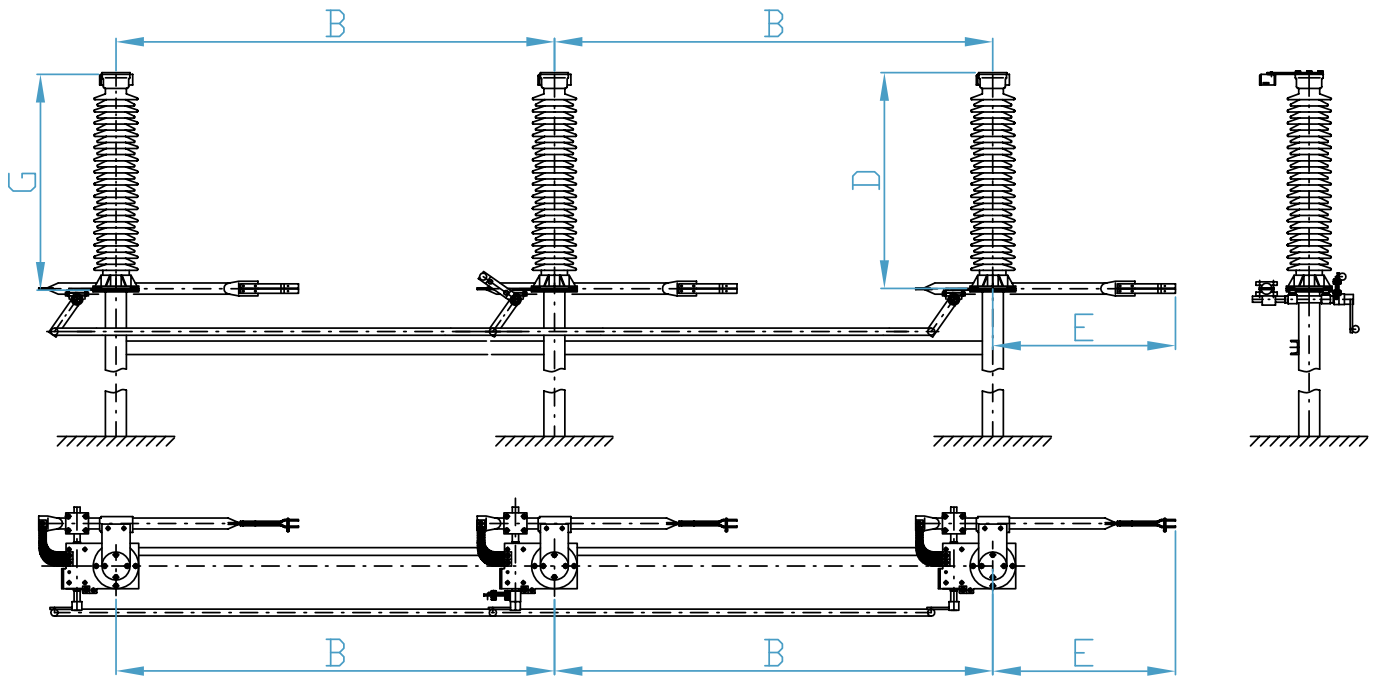

## Dimensions

Ur = 123 kV	B	D	G	E
	2900	1220	1240	1040

## Technical data

Rated voltage	123 kV
Rated current	Up to 3150 A
Rated short-circuit current	Up to 50 kA (1s)
Rated peak withstand current	Up to 125 kA
Power frequency withstand voltage AC 50 Hz, 1 min – against ground	230 kV
Power frequency withstand voltage AC 50 Hz, 1 min – across isolating distance	265 kV
Rated lightning impulse withstand voltage 1.2/50 $\mu$ s – against ground	550 kV
Rated lightning impulse withstand voltage 1.2/50 $\mu$ s – across isolating distance	630 kV

# 245 kV type 1SUJ

## up to 3150 A, 50 kA/125 kA

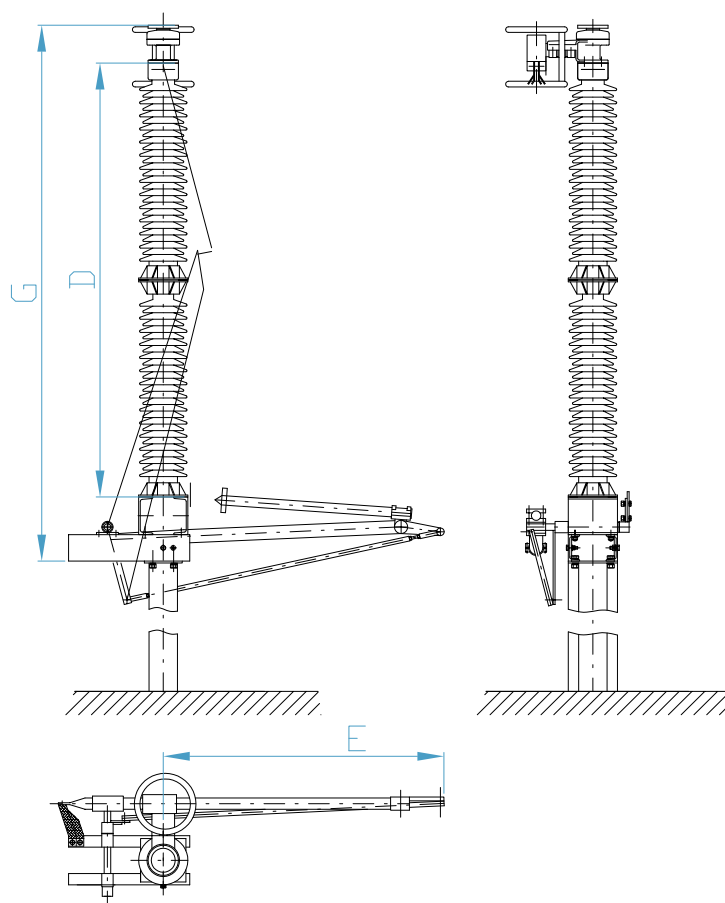

### Dimensions

Ur = 245 kV	D	G	E
	2650	2840	1400

### Technical data

Rated voltage	245 kV
Rated current	Up to 3150 A
Rated short-circuit current	Up to 50 kA (1s)
Rated peak withstand current	Up to 125 kA
Power frequency withstand voltage AC 50 Hz, 1 min – against ground	460 kV
Power frequency withstand voltage AC 50 Hz, 1 min – across isolating distance	530 kV
Rated lightning impulse withstand voltage 1.2/50 $\mu$ s – against ground	1050 kV
Rated lightning impulse withstand voltage 1.2/50 $\mu$ s – across isolating distance	1200 kV

# 420 kV type 1SUJ up to 3150 A, 50 kA/125 kA

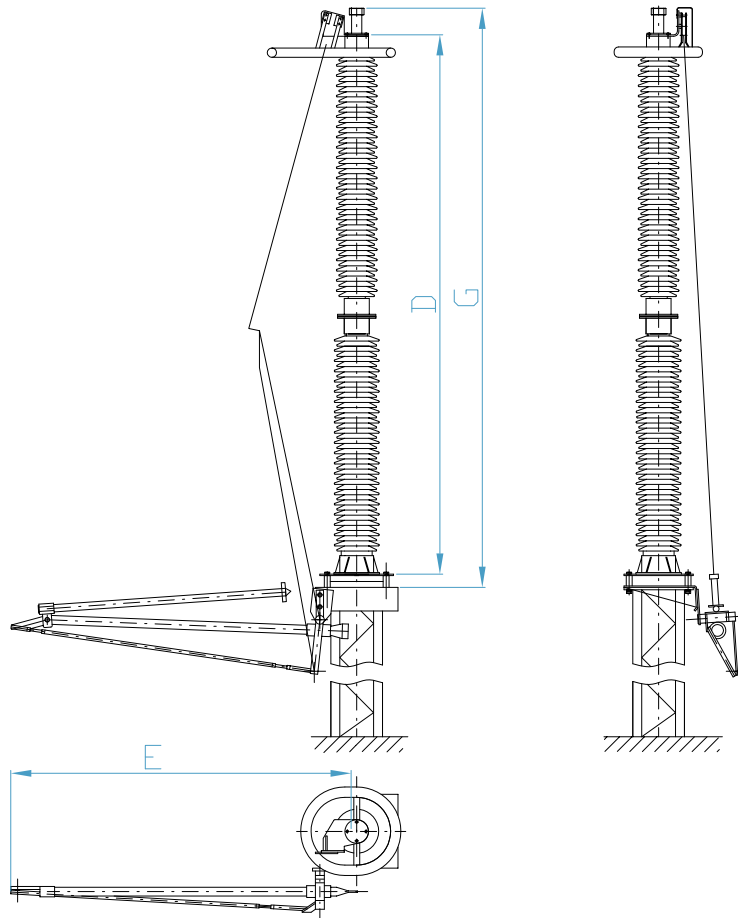

## Dimensions

Ur = 420 kV	D	G	E
	3650	3940	2300

## Technical data

Rated voltage	420 kV
Rated current	Up to 3150 A
Rated short-circuit current	Up to 50 kA (1s)
Rated peak withstand current	Up to 125 kA
Power frequency withstand voltage AC 50 Hz, 1 min – against ground	520 kV
Power frequency withstand voltage AC 50 Hz, 1 min – across isolating distance	610 kV
Rated lightning impulse withstand voltage 1.2/50 $\mu$ s – against ground	1425 kV
Rated lightning impulse withstand voltage 1.2/50 $\mu$ s – across isolating distance	1425 (+240) kV

# 420 kV type 3SUJ up to 4000 A, 63 kA/160 kA

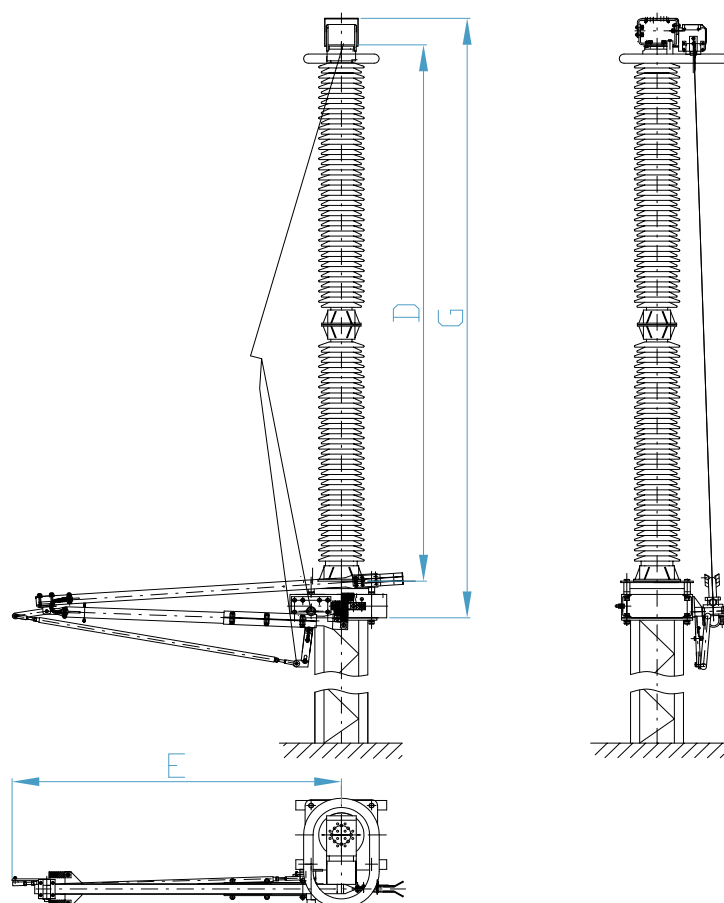

## Dimensions

Ur = 420 kV	D	G	E
	3650	4090	2300

## Technical data

Rated voltage	420 kV
Rated current	Up to 4000 A
Rated short-circuit current	Up to 63 kA (1s)
Rated peak withstand current	Up to 160 kA
Power frequency withstand voltage AC 50 Hz, 1 min – against ground	520 kV
Power frequency withstand voltage AC 50 Hz, 1 min – across isolating distance	610 kV
Rated lightning impulse withstand voltage 1.2/50 $\mu$ s – against ground	1425 kV
Rated lightning impulse withstand voltage 1.2/50 $\mu$ s – across isolating distance	1425 (+240) kV

# Motor drives

## for a reliable operation

### Features

- Control voltage variants: 230 VAC, 220 VDC, 110 VDC, 60 VDC
- Motor voltage variants: 400 VAC, 230 VAC, 110 VDC, 220 VDC
- High corrosion protection thanks to stainless steel
- Local, remote and manual control
- Easy to access connection terminal strips
- Anti-corrosion heating
- On/off/isolating layer signaling
- Lead signal
- For using different disconnecter-types



Motordrive PMA2, PMA3, PMA5, PMA6



Motordrive PMR5, PMR6, PMR7

## PMA2, PMA5 – Technical data

	PMA2	PMA5
Rated control voltage	230 VAC, 220 VDC, 110 VDC	
Rated motor voltage	3x230/ 400 V, 50 Hz	230 VAC, 220 VDC, 110 VDC
I <sub>max</sub>	5A	9A
I <sub>r</sub>	2A	1.5 A
Thermal resistor power consumption	2x30 W/ 230 VAC	
Auxiliary switch	6 On, 6 Off, 2 Isolating layer 12 On, 12 Off, 2 Isolating layer	
Motor operation	5s	
Maximum shaft torque	700 Nm	750 Nm
Motor	550 W	630 W
Housing protection class	IP 54	
Weight	63 kg	
Dimensions HxWxD	670x440x404	
Shaft	Horizontal, 192°	
Drive mounting	On the support table	
Gear type	Worm gear	

## Diagram

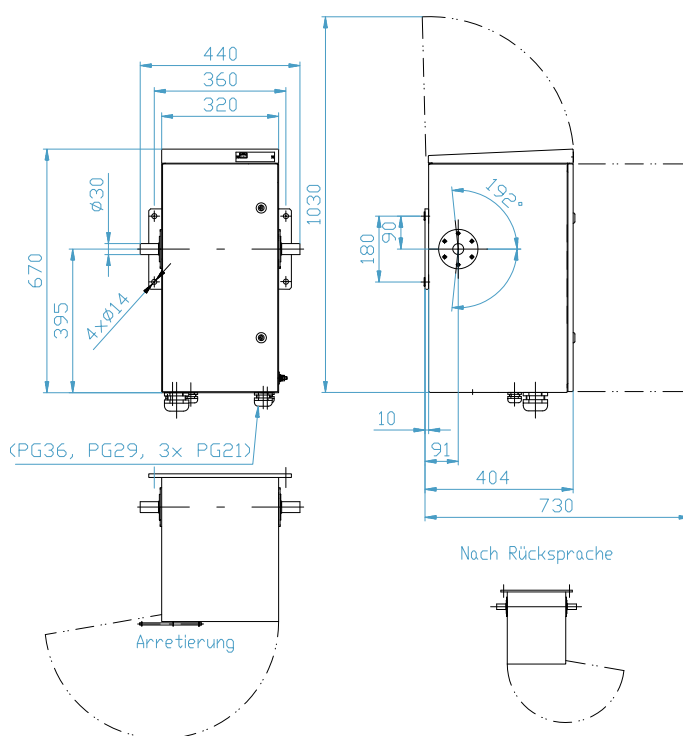

## PMR5, PMR6 - Technical data

Rated control voltage	230 VAC, 220 VDC, 110 VDC, 60 VDC
Rated motor voltage	230 VAC
I max	10 A/ 20 A
I r	2.3 A/ 3.9 A
Thermal resistor power consumption	2x30 W/ 230 VAC
Auxiliary switch	7 On, 7 Off, 2 Isolating layer
Motor operation	8s
Motor	1 f/ 630 W
Housing protection class	IP 54
Weight	74 kg
Dimensions HxWxD	737x500x305
Shaft	Vertical, 90°
Drive mounting	On the frame/support table
Gear type	Screw gear

## Diagram

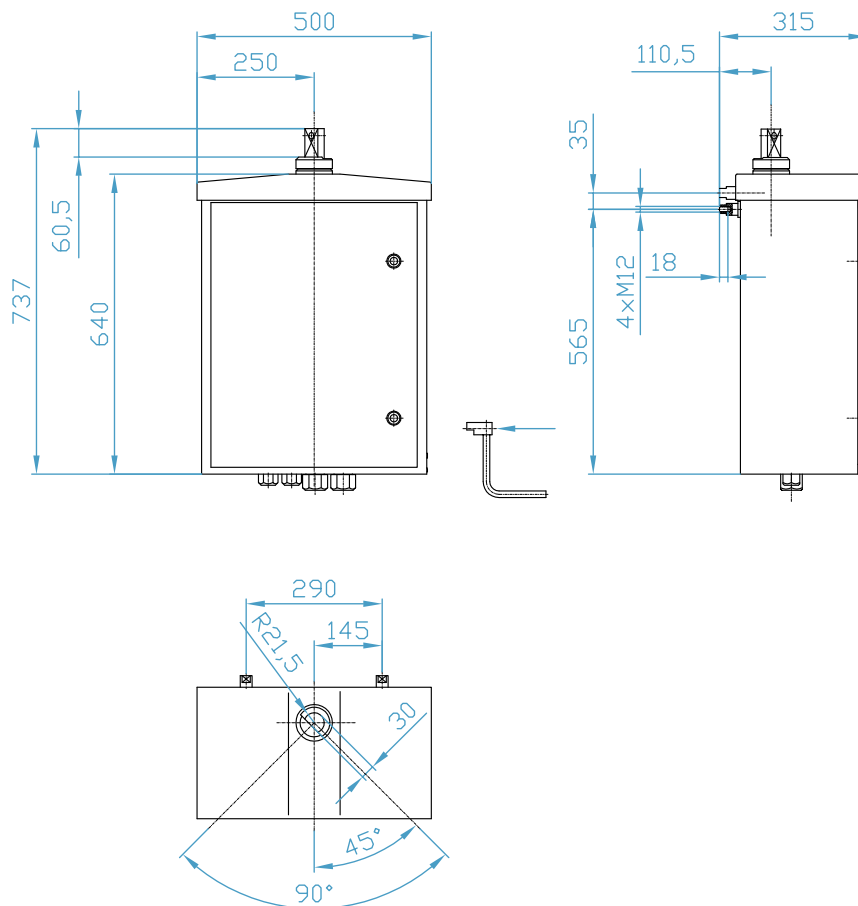

## PMA3, PMA6 - Technical data

	PMA3	PMA6
Rated control voltage	230 VAC, 220 VDC, 110 VDC	
Rated motor voltage	3x230/ 400 V, 50 Hz	230 VAC, 220 VDC, 110 VDC
I max	6A	9A
I r	2A	2A
Thermal resistor power consumption	1x30 W + 1x50 W	1x100 W
Auxiliary switch	6 On, 6 Off, 2 Isolating layer 12 On, 12 Off, 2 Isolating layer	
Motor operation	8s	
Maximum shaft torque	1300 Nm	
Motor	550 W	630 W
Housing protection class	IP 54	
Weight	85 kg	
Dimensions HxWxD	760x456x485	
Shaft	Horizontal, 192°	
Drive mounting	On the support table	
Gear type	Worm gear	

## Diagram

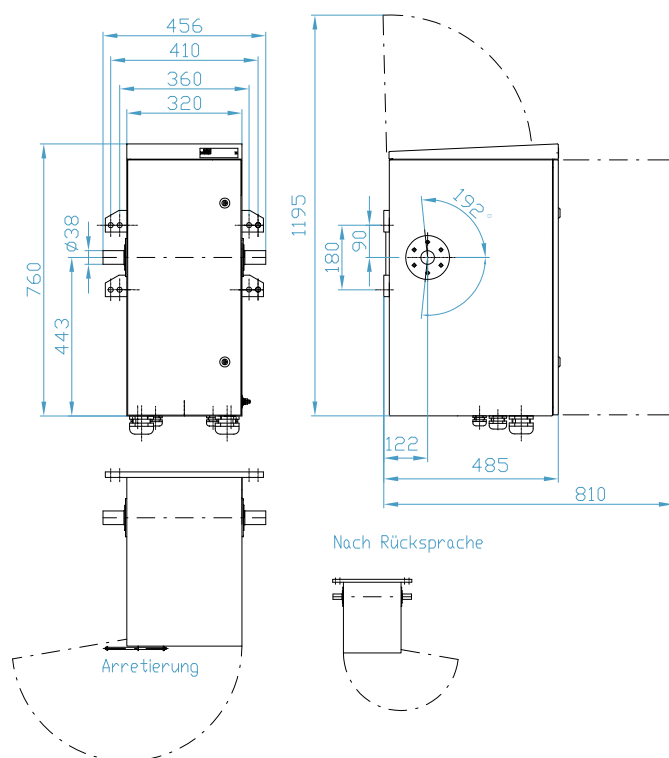

# Motor drive mounting options

The drive can be mounted on the frame and support table. The design depends on the project and customer specification.

We can quickly and flexibly respond to your requests. Together, we always find the right solution.

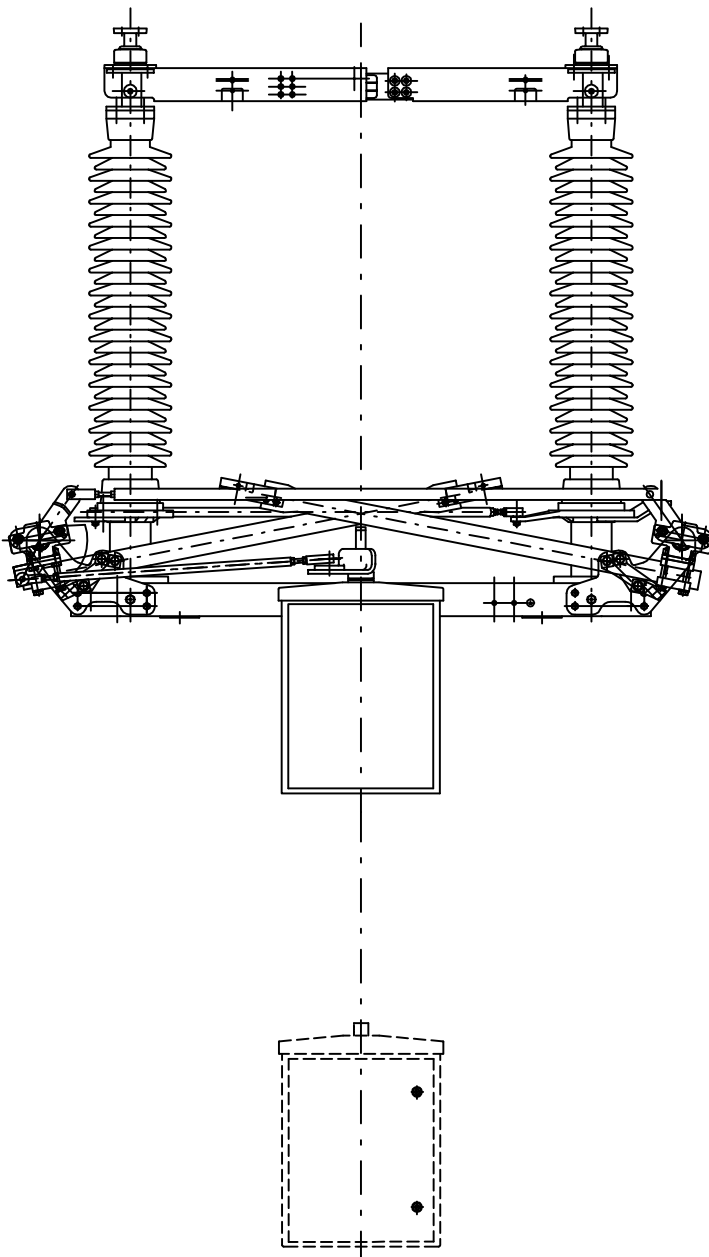

Drive on the frame

Drive on the support table

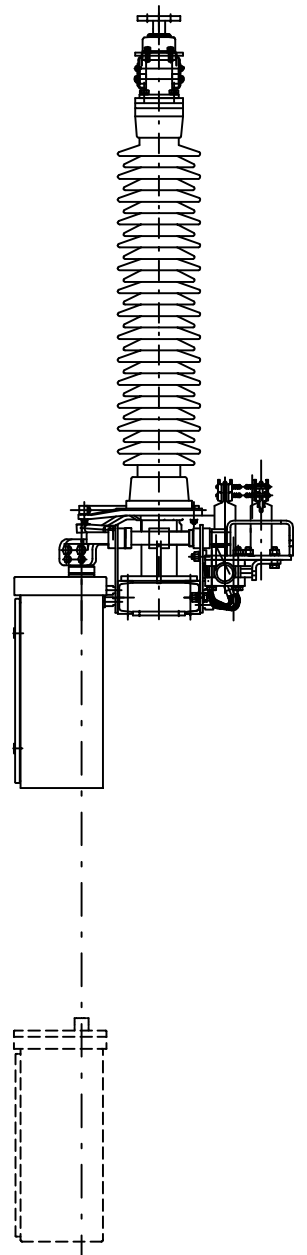

# Services

## Customized to your needs

Highly-motivated and superbly trained employees are the key to ensuring high quality standards.

SERW offers comprehensive services for high-voltage switchgear and supports installations throughout the entire product lifecycle – from the installation through to inspection.

Our highly qualified employees at our factory have decades of experience in service and are renowned for their high-quality work.

We tailor our services to meet our customers' needs. We will be happy to implement the service work for you directly in your transformer station. We also train our customers' personnel so that they can independently perform the installation and inspection work.



Our comprehensive range of services

# SERW as a company of R&S

## An international group

The R&S companies are united by their common long-standing experience and expertise in the production of power products, as well as their hunger for progress.

Founded in 2012, the R&S Group is an international group headquartered in Sissach, Switzerland with branches all over the world.

This results in premium-quality products and the highest possible degree of reliability for our customers.

### The success of R&S is built on:

- Long-standing experience of the associated companies in their respective product sectors
- A highly motivated and excellently trained workforce
- Products based on proven technologies that go hand in hand with innovative and efficient manufacturing processes

### Companies of R&S

- Rauscher & Stoecklin: Distribution transformers, overhead line switches, high-current plug-in connectors, switchgears
- SERW: High-voltage and medium-voltage switchgear
- ZREW: Power transformers
- Tesar: Cast-resin, distribution transformers, measuring transducers

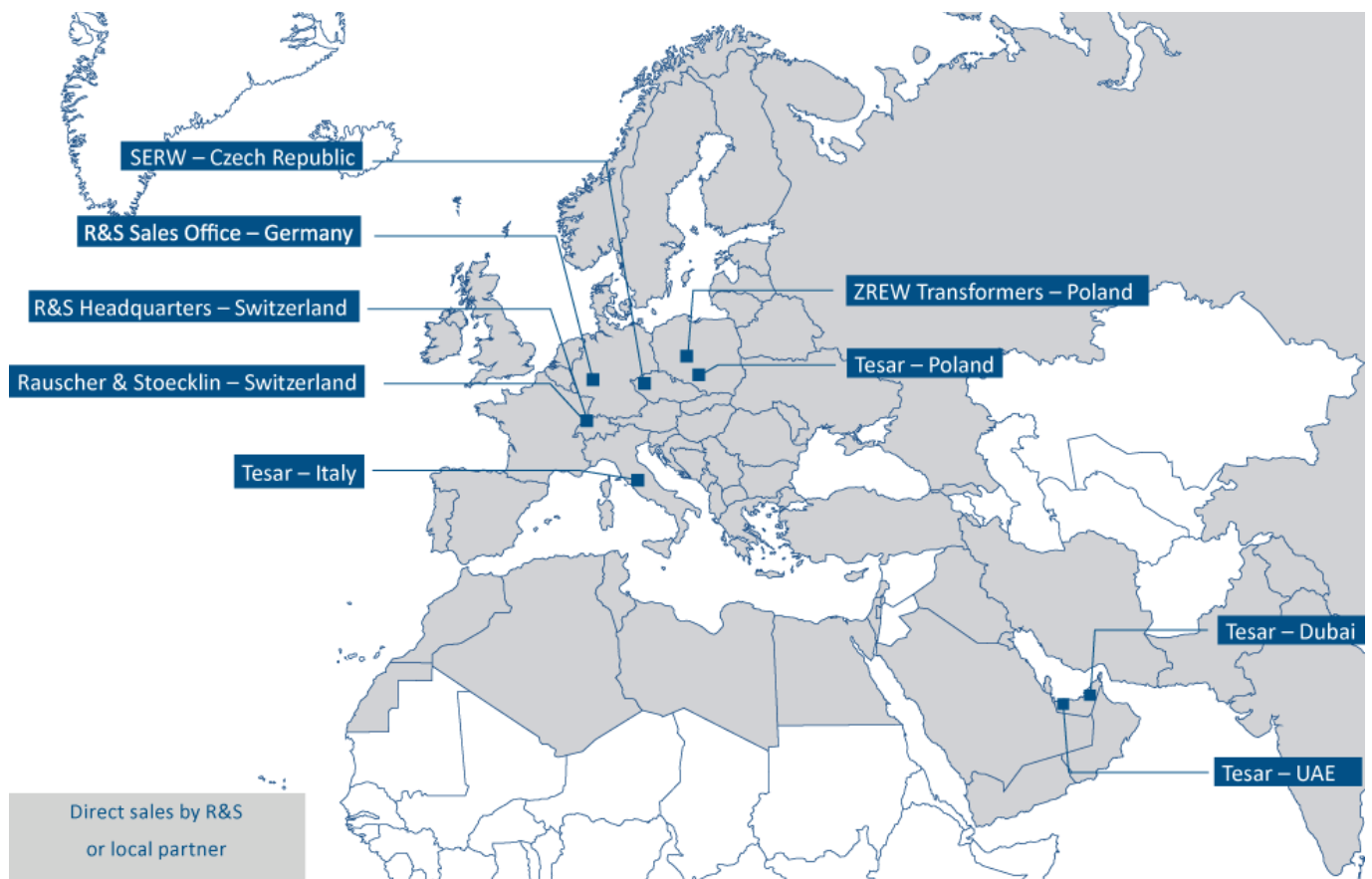

Our branches worldwide

# Companies of the R&S Group

## **R&S International Holding**

Reuslistrasse 32  
4450 Sissach  
Switzerland  
info@the-rsgroup.com  
www.the-rsgroup.com

## **Rauscher & Stoecklin**

Reuslistrasse 32  
4450 Sissach  
Switzerland  
info@raustoc.ch  
www.raustoc.ch

## **SERW**

Tymákovská 42, Sedlec  
332 02 Starý Plzenec  
Czech Republic  
serw@serw.cz  
www.serw.cz

## **ZREW Transformers**

ul. Rokicińska 144  
92-412 Łódź  
Poland  
transformatory@zrew-tr.pl  
www.zrew-transformatory.pl

## **Tesar**

Loc. Chiaveretto  
52010 Subbiano – Arezzo  
Italy  
info@tesar.eu  
www.tesar.eu

## **Tesar Polska**

ul. Skarbowska 34  
32-005 Niepołomice  
Poland  
info@tesarpolska.pl  
www.tesarpolska.pl

---

## **SERW, spol. s r.o.**

Tymákovská 42, Sedlec  
CZ-332 02 Starý Plzenec

T +420 377 966 451 serw@serw.cz  
F +420 377 966 621 www.serw.cz