

RIBE[®]

ELECTRICAL FITTINGS



CATENARY COMPONENTS FOR LOCAL TRANSPORT SYSTEMS



RIBE® – a family business where tradition meets entrepreneurship and innovation

Johannes Wilhelm Hofmann founded his "Fabrik elektrischer Apparate" in Kötschenbroda (now Radebeul) near Dresden on 2 December 1902, which means it is the oldest manufacturer of electrical fittings in the world. The company was involved from the start in manufacturing products for connecting all kinds of electrical wires, with the aim of positioning itself as a full-range supplier with a comprehensive depth of manufacturing and technology at a very early stage.

RIBE® as legal successor took over all the patents and the technical know-how and developed the business unit to its present level of international importance as Richard Bergner Elektroarmaturen GmbH & Co. KG.

The RIBE® Group is one of today's leading international suppliers of electrical fittings, mechanical fasteners and technical springs. It employs a workforce of about 1,500 at nine locations and achieves a total sales volume of over 130 million euros.

Since 1949, electrical fittings have been supplied for

- local transport systems (tram, trolleybus)
- industrial and mining railways and
- standard-gage railways (Deutsche Reichsbahn).

Since then, RIBE® has produced a full range of electrical fittings for a wide variety of catenary systems.

These have been supplied for many large projects, such as the electrification of 3,800 km for the Deutsche Reichsbahn

network taken into service up to the end of 1991.

Major changes have taken place in the field of local transport catenary systems over the past years due to the use of corrosion-resistant materials and changes in design principles.

In order to meet these new requirements and offer our customers modern electrical fittings specifically designed for local transport systems, we have cooperated with AEG to develop a range of electrical fittings that can provide all the necessary subassemblies for a local transport line from a small number of corrosion-resistant components.

This has been achieved by a modular design of the range of electrical fittings and subassemblies based on the following principles:

- Installation of tensioned contact wires with bridle-type suspension
- Use of GRP steady arms and curve pull-offs
- Creation of cross-span equipment with Minoroc ropes (all-insulated) or metal ropes with double or triple insulation
- Use of GRP rods or tubes with a diameter of 55 or 70 mm for cantilevers
- Use of only one type of clamp for both diameters of the GRP rod or tube
- Fixing to the pole with pole cable loops, with swivel brackets and hinges for cantilevers and stainless steel punch-lock band or wall fixing.

Design of subassemblies Cross-span equipment

All cross-span equipment can be designed as plain, stitch suspension, double stitch suspension or as a horizontal catenary contact line of Minoroc rope without insulators or with double- or triple-insulated metal ropes. The initial insulation is the bridle-and-pulley suspension or an insulated line hanger.

Figure 1 Cross-span equipment, stitch suspension, with various components and insulation

- 030 **T/NTC¹**
all-insulated, Minoroc rope
- 031 **Cu-T/NTC¹**
double-insulated, rope 50
- 032 **Cu-T/NTC¹**
triple-insulated, rope 50
- 033 **Cu-T/NTC¹**
double-insulated, rope 35
- 034 **Cu-T/NTC¹**
triple-insulated, rope 35
- 035 **A2-T/NTC¹**
double-insulated, rope 50
- 036 **A2-T/NTC¹**
triple-insulated, rope 50
- 037 **A2-T/NTC¹**
double-insulated, rope 35
- 038 **A2-T/NTC¹**
triple-insulated, rope 35
- 039 **Wedge-type dead end clamp**
double-insulated, rope 50
- 040 **Wedge-type dead end clamp**
triple-insulated, rope 50
- 041 **Wedge-type dead end clamp**
double-insulated, rope 35
- 042 **Wedge-type dead end clamp**
triple-insulated, rope 35

¹T/NTC = Thimble and Notch Type Connector

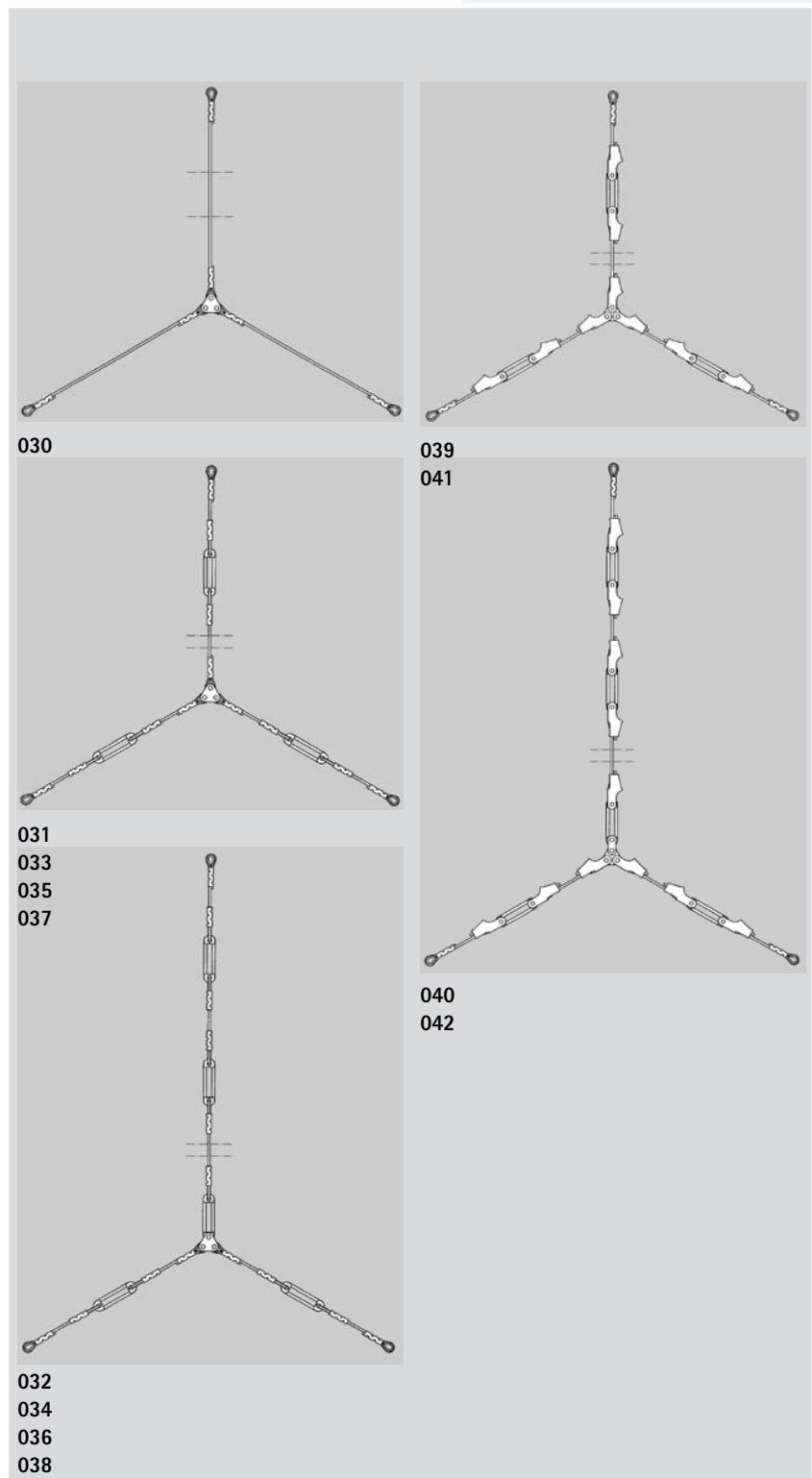

Support points for trolley-type contact lines

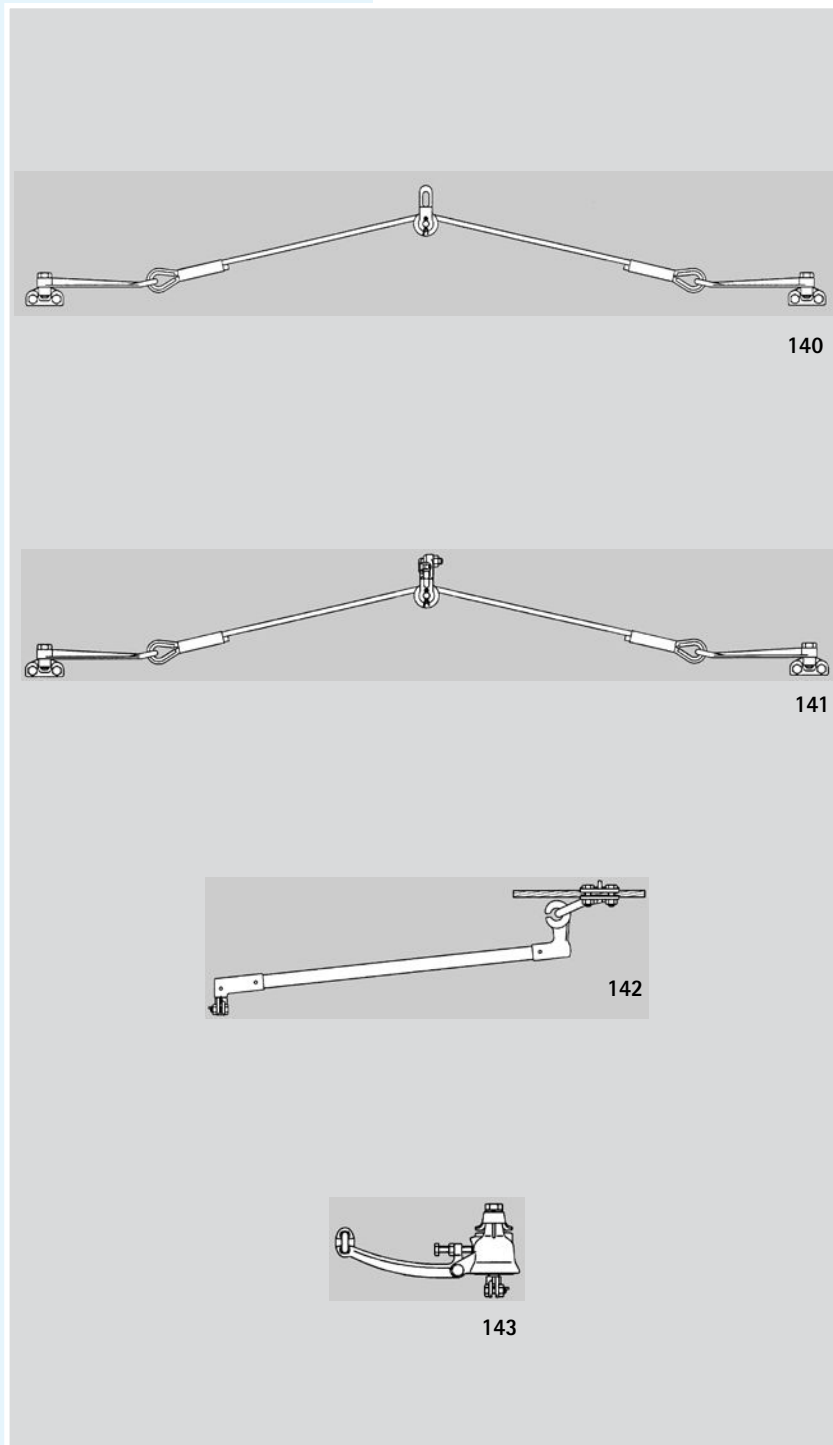

The bridge-and-pulley suspension with Minoroc rope and lengths of 2.0 ... 5.0 m is the most important support point variant used for the tensioned trolley-type contact line at both the cantilever and the cross-span equipment.

Depending on the requirement, this suspension variant can be combined with a GRP steady arm.

Figure 2 Bridge-and-pulley suspensions for cantilever and cross-span equipment
GRP steady arm on the cross-span wire

- 140 **Bridge-and-pulley suspension for cantilever support**
- 141 **Bridge-and-pulley suspension for cross-span equipment**
- 142 **Steady arm for bridge-and-pulley suspension in cross-span equipment**
- 143 **Insulated line hanger**

$$F_{SMFL} = 2.5 \text{ kN}$$

Curve pull-offs

Curve pull-offs are provided with GRP steady arms with lengths of 600... 1,200 mm. The GRP rods have a diameter of 26 mm. A wide range of variants to meet all requirements can also be made here using only a few components. Double curve pull-offs are used for forces larger than 2.5 kN. These are also made with GRP steady arms, whose hooks are angled at 90° to the clamp holders. The curve pull-offs can be used for 2 contact wires similar to these solutions.

Figure 3 Single and double curve pull-offs for 1 contact wire

- 200** **Cu-T/NTC²**
single, all-insulated, Minoroc rope
- 201** **Bz 35 II, Cu-T/NTC²**
single, double-insulated
- 202** **Bz 35 II, Cu-T/NTC²**
single, triple-insulated
- 203** **Bz 35 II, wedge-type dead end clamp**
single, double-insulated
- 204** **Bz 35 II, wedge-type dead end clamp**
single, triple-insulated
- 205** **Cu-T/NTC²**
double, all-insulated, Minoroc rope
- 206** **Bz 35 II, Cu-T/NTC²**
double, double-insulated
- 207** **Bz 35 II, Cu-T/NTC²**
double, triple-insulated
- 208** **Bz 35 II, wedge-type dead end clamp**
double, double-insulated
- 209** **Bz 35 II, wedge-type dead end clamp**
double, triple-insulated
- 210** **A2-T/NTC²**
single, all-insulated, Minoroc rope
- 211** **Bz 35 II, A2-T/NTC²**
single, double-insulated
- 212** **Bz 35 II, A2-T/NTC²**
single, triple-insulated
- 213** **A2-T/NTC²**
double, all-insulated, Minoroc rope
- 214** **Bz 35 II, A2-T/NTC²**
double, double-insulated
- 215** **Bz 35 II, A2-T/NTC²**
double, triple-insulated

²T/NTC = Thimble and Notch Type Connector

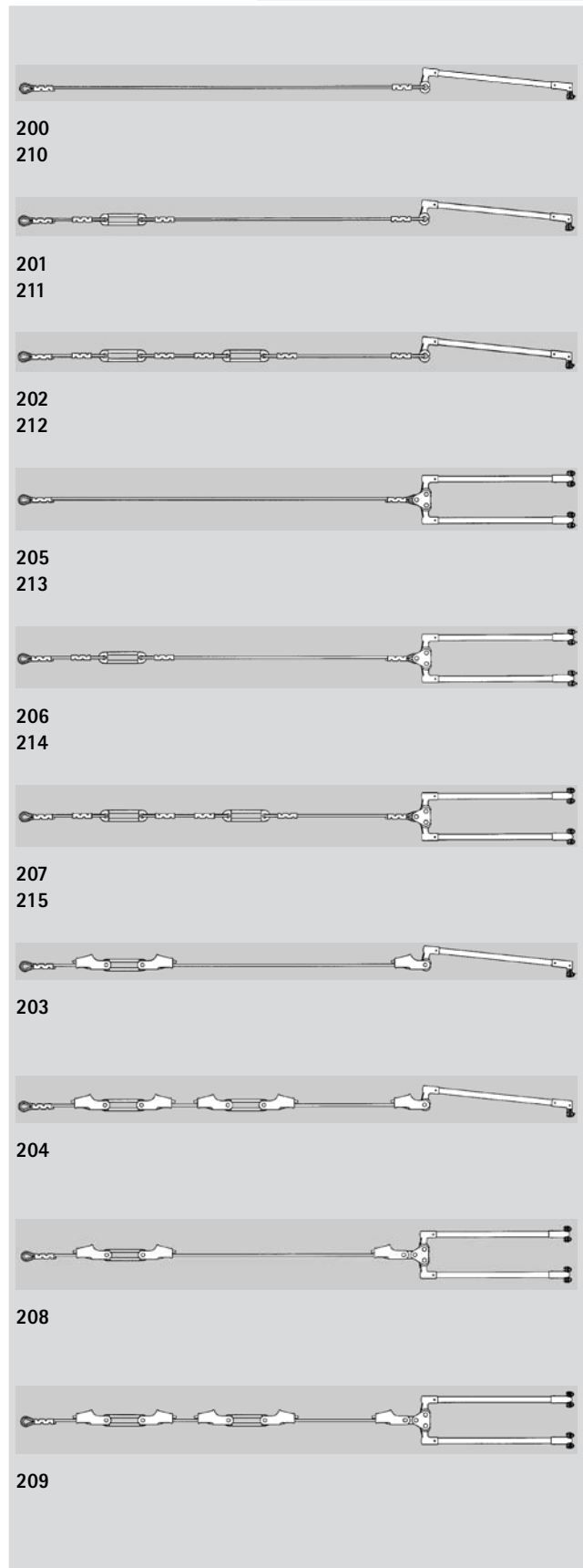

GRP cantilever support for punch-lock band fixing

All the cantilever variants shown, which consist of one or two GRP rods with a diameter of 55 ... 70 mm, can be made from as few as 20 different parts. This small number of parts is achieved by the use of clamps that can be used almost unchanged for both GRP rod diameters and for the different numbers of rods.

All parts are also used on cantilevers for overhead contact lines. The cantilevers can be completed with various attachments like pull-off fittings with steady arm and/or bridle-and-pulley suspensions.

Figure 4 GRP cantilever supports and associated tensions

- 150 GRP cantilever support**
single-tracked, tube 55
- 151 GRP cantilever support**
single-tracked, tube 70
- 152 GRP cantilever support**
double-tracked, tube 55
- 153 GRP cantilever support**
double-tracked, tube 70
- 154 GRP cantilever support**
double-tracked, 2 tubes 55
- 155 GRP cantilever support**
double-tracked, 2 tubes 70
- 160 Tension for cantilever support**
single tension, Minoroc rope
- 161 Tension for cantilever support**
double tension, Minoroc rope
- 162 Tension for cantilever support**
single tension, rope Bz 35 II
- 163 Tension for cantilever support**
double tension, rope Bz 35 II

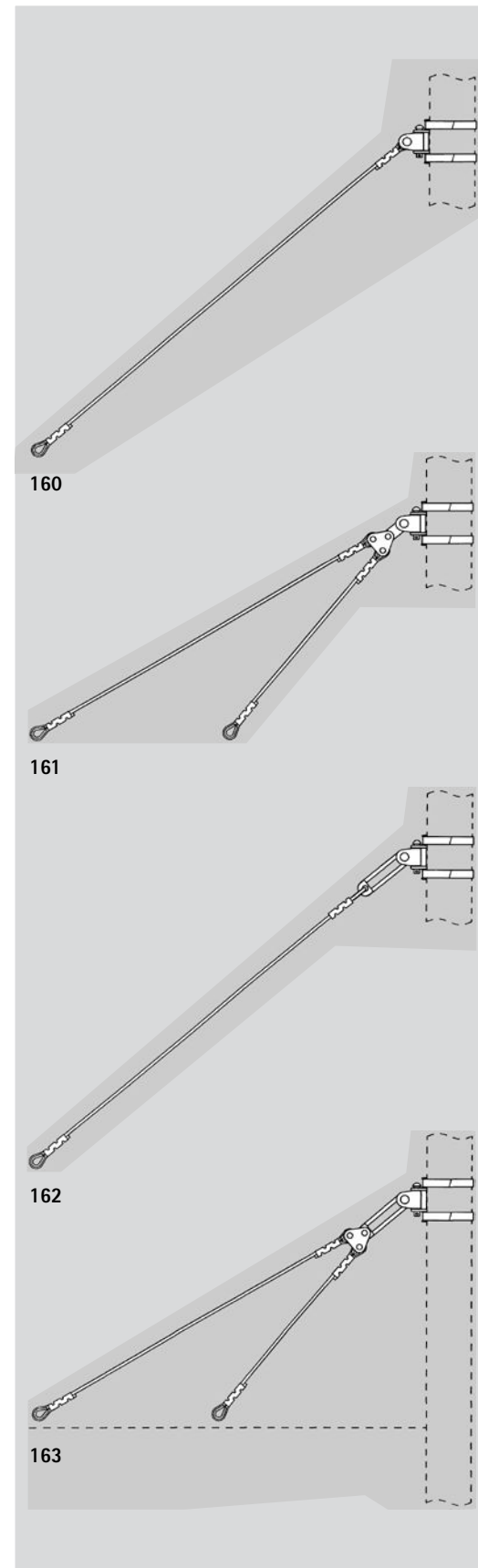

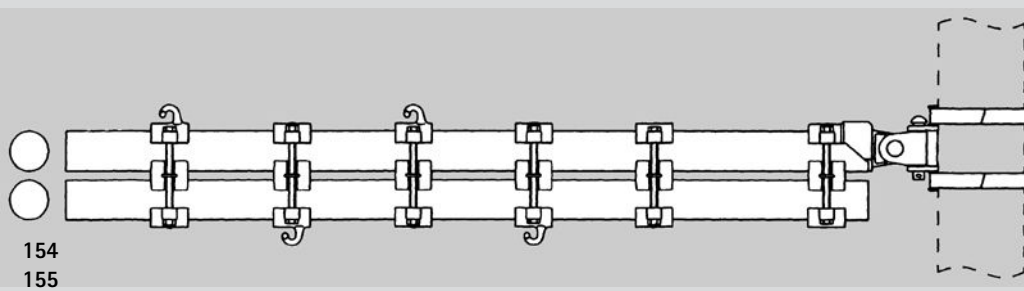
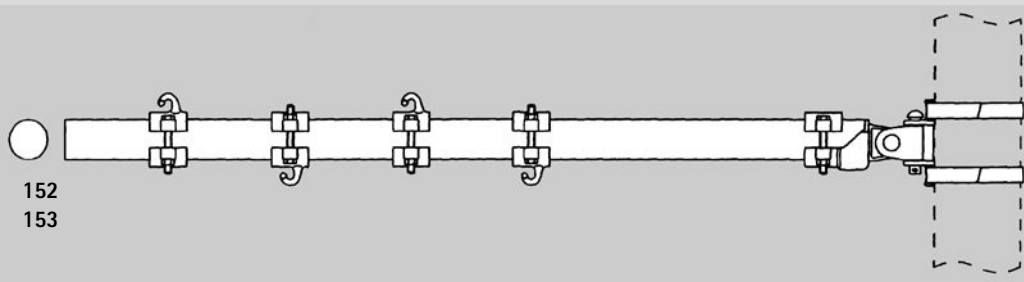
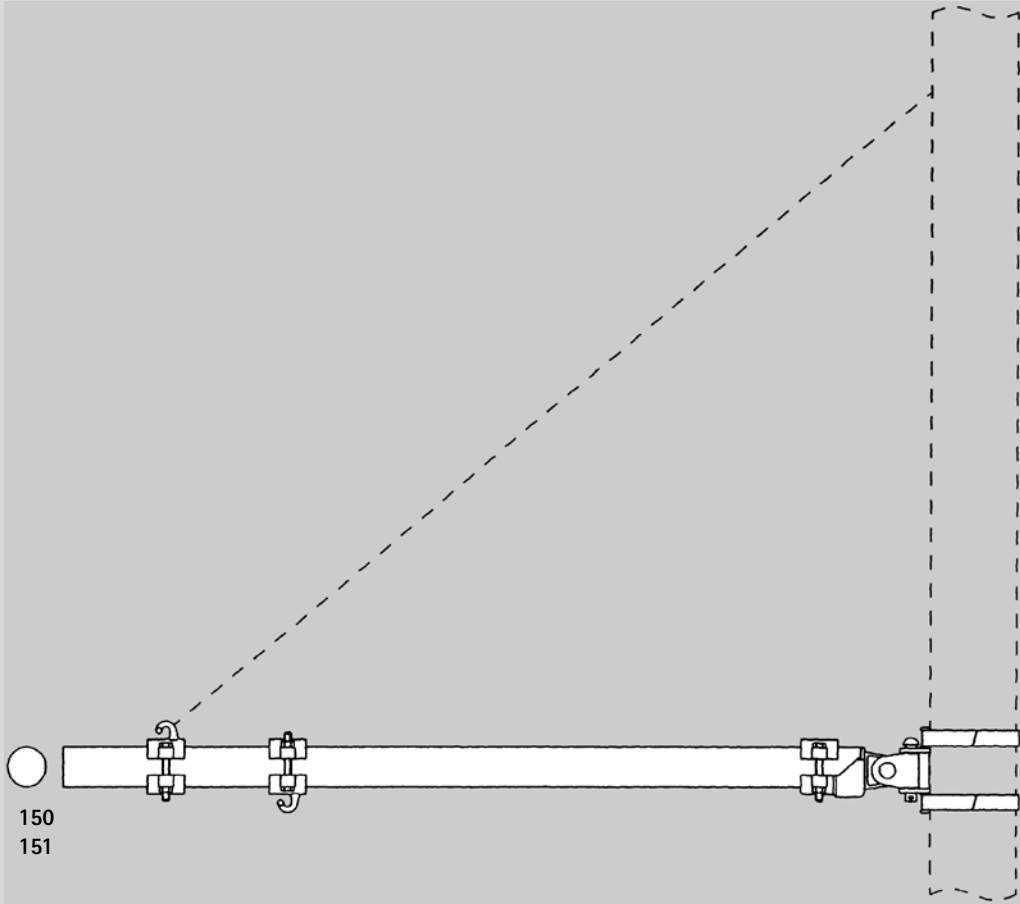

GRP cantilevers for overhead contact lines

With the exception of the catenary wire support clamp, which is available in variants for one or two GRP rods/tubes with a diameter of 55 mm or 70 mm and one or two messenger wires with cross-sections of 50 and 70 mm² and 95 ... 150 mm², the GRP cantilevers for overhead contact lines are produced from the same components as the GRP cantilever supports. They can also be equipped with diagonal tubes if necessary.

The modular design enables more than 70 different variants of cantilevers to be produced with the necessary 24 components. As the connecting dimensions of all parts comply with DIN standards, the variants can also be combined with existing parts. They can naturally be assembled as all-insulated with Minoroc rope and with metal ropes and insulators.

A special advantage is that the catenary wire support clamp can be slid along the GRP rod/tube.

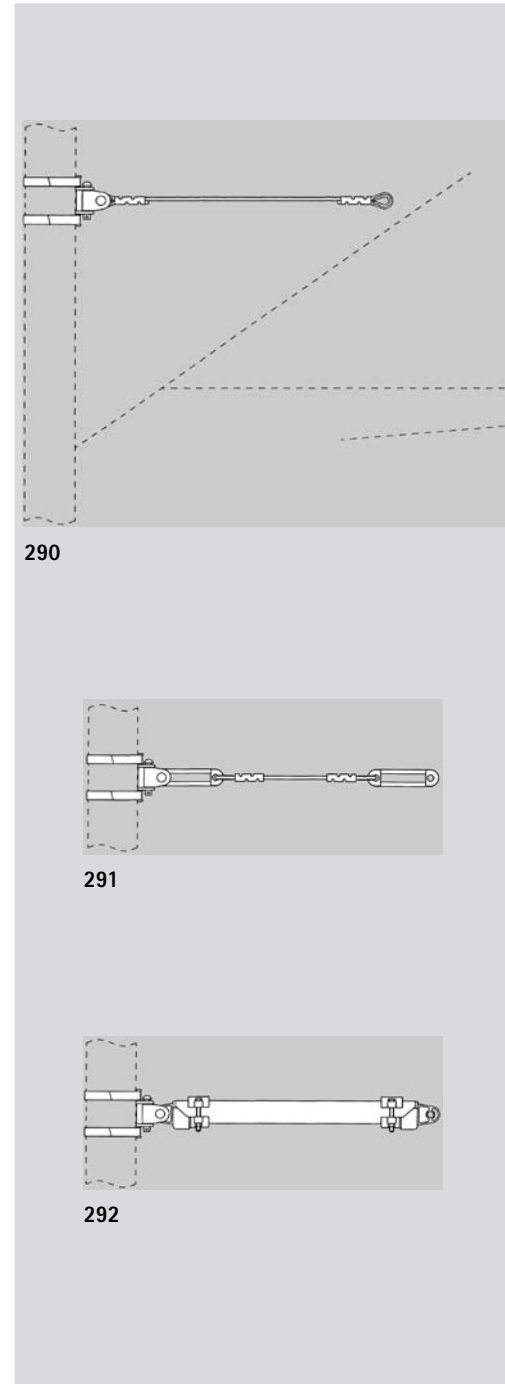
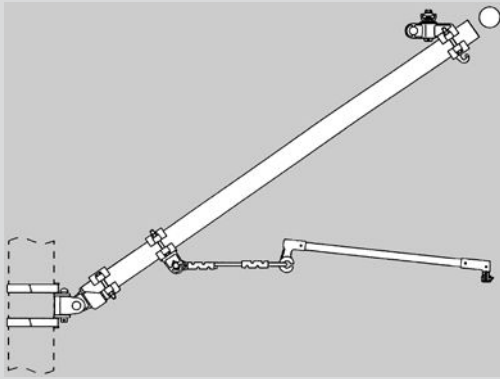
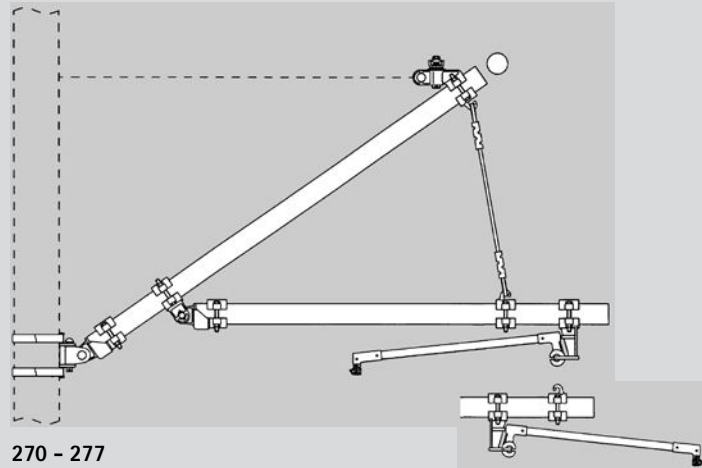

Figure 5 Peak bracings for GRP cantilevers for overhead contact lines

- 290** **Peak bracing**
All-insulated with Minoroc rope
- 291** **Peak bracing**
Double-insulated, rope Bz 35 II
- 292** **Peak bracing**
All-insulated with GRP rod



250 - 257



270 - 277

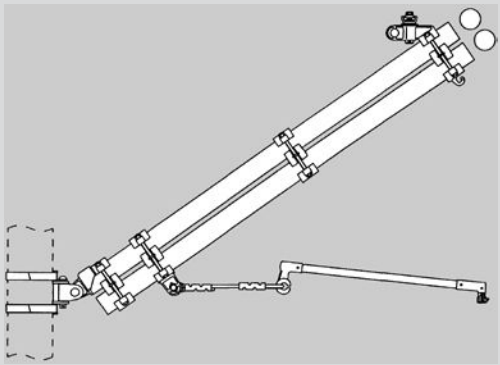

260 - 267

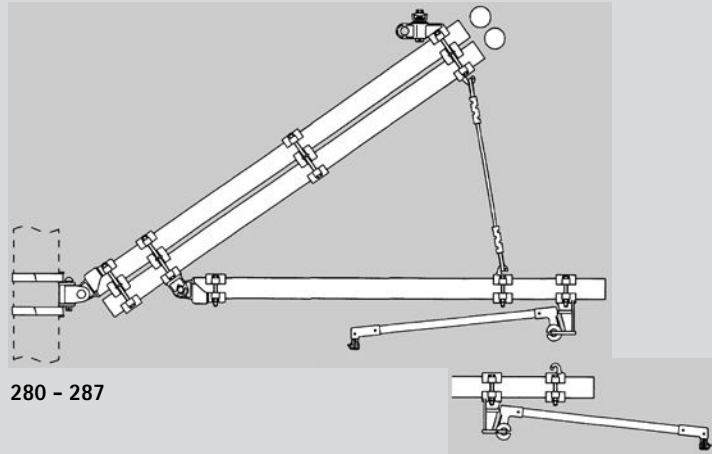

280 - 287

Figure 6 GRP cantilevers for overhead contact lines with and without registration tube

250 - 257 Without registration tube
for 1 tube Ø 55 or Ø 70
messenger wire 50 mm² to 150 mm²

270 - 277 With registration tube
for 1 tube Ø 55 or Ø 70
messenger wire 50 mm² to 150 mm²

260 - 267 Without registration tube
for 2 tubes Ø 55 or Ø 70
messenger wire 50 mm² to 150 mm²

280 - 287 With registration tube
for 2 tubes Ø 55 or Ø 70
messenger wire 50 mm² to 150 mm²

Overview of components

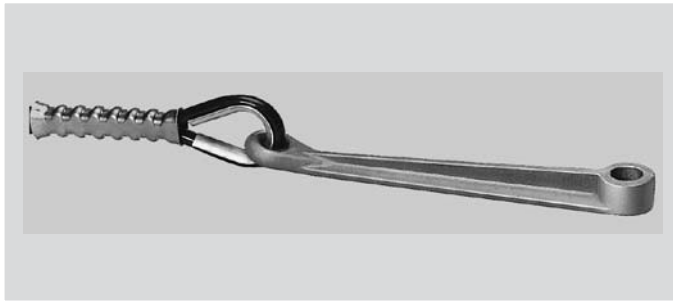

Pull-off arm

Order no. 511 912 1.201

Application: Pull-off arm for bridle-and-pulley suspension with M 16 contact wire clamp

Technical parameters: Material: copper alloy
 $F_{SMDL} = 3.5 \text{ kN}$



Pulley

Order no. 511.941.1

Application: Pulley for bridle-and-pulley suspension and messenger wire up to $\varnothing 9 \text{ mm}$

Technical parameters: Material: copper alloy
 Pulley polyamide
 $F_{SMDL} = 3.0 \text{ kN}$

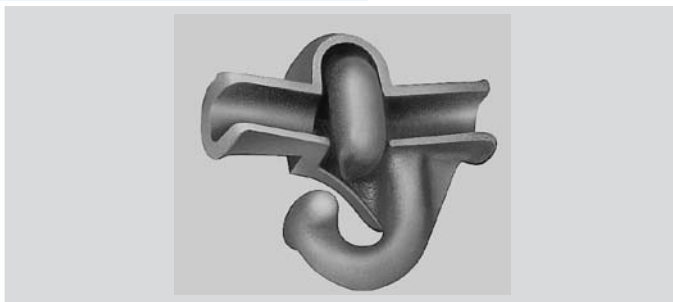

Suspension clamp

Order no. 533.113.1

Application: Suspension for bridle-and-pulley suspension on cross-span equipment, fixing dropper on head-span wire

Technical parameters: Material: copper alloy
 Clip bolt A2
 $F_{SMDL} = 1.5 \text{ kN}$ for rope up to 50 mm²

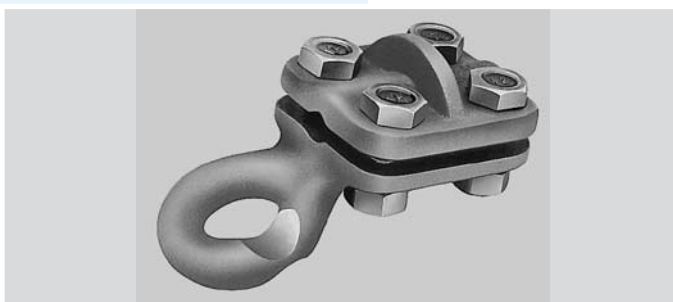

Ring clamp

Order no. 534.119.1

Application: Fixing of curve pull-offs or GRP steady arms on cross-span wire

Technical parameters: Material: copper alloy
 Pull-off force: $F_{SMFL} = 5 \text{ kN}$ for rope 35 mm²... 70 mm²

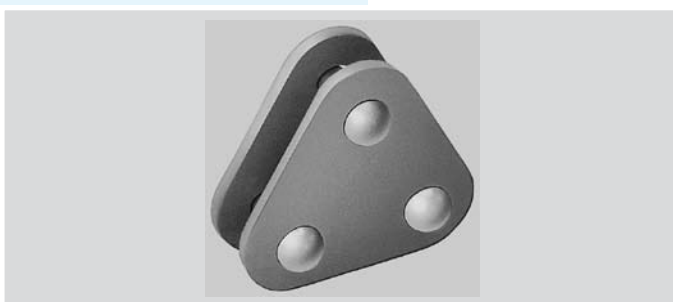

Triangle double clip 13 Cu

Order no. 537.421.2

Application: All-purpose bracing element

Technical parameters: Material: Cu
 Strap distance: 18.5 mm
 $F_{SMDL} = 10 \text{ kN}$

GRP steady arm, regular

Order no. 525.212.1

Application: GRP steady arm for cantilevers and curve pull-offs

Technical

parameters:

Material: connecting fittings copper alloy

Length: 0.6... 1.2 m

$F_{SMDL} = 2.5 \text{ kN}$

Suitable for $U = 1.5 \text{ kV DC}$ for a length $\geq 0.6 \text{ m}$

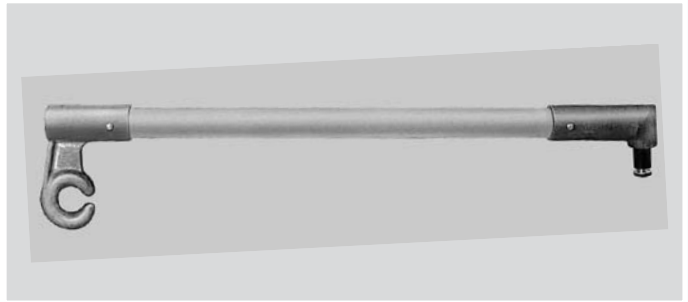

GRP steady arm, angled 180°

Order no. 525.211.1

Application: GRP steady arm for fixing to cross-span equipment and cantilever

Technical

parameters:

Material: connecting fittings copper alloy

Length: 0.6... 1.2 m

$F_{SMDL} = 2.5 \text{ kN}$

Suitable for $U = 1.5 \text{ kV DC}$ for a length $\geq 0.6 \text{ m}$



GRP steady arm, angled 90° right or left

Order no. 525.213.1 (angled right)

Order no. 525.214.1 (angled left)

Application: GRP steady arm for double curve pull-off

Technical

parameters:

Material: connecting fittings copper alloy

Length: 0.6... 1.2 m

$F_{SMDL} = 2.5 \text{ kN}$

Suitable for $U = 1.5 \text{ kV DC}$ for a length $\geq 0.6 \text{ m}$



Swivel bracket and hinge for cantilever

Order no. 529.218.1

Application: Swivel bracket and hinge for cantilever for taut-band fixing to round or hexagonal/octagonal pole

Technical

parameters:

Material: copper alloy

$F_{SMDL} = 16 \text{ kN}$

Max. width of punch-lock band: 25 mm



Tube end fitting with eye

Order no. 521.151.1

Application: Connecting piece for GRP rod/tube with $\varnothing 55$ or 70 mm

Technical

parameters:

Material: copper alloy

$F_{SMDL} = 5 \text{ kN}$

referred to the start of slipping of a GRP rod with $d = 55 \text{ mm}$

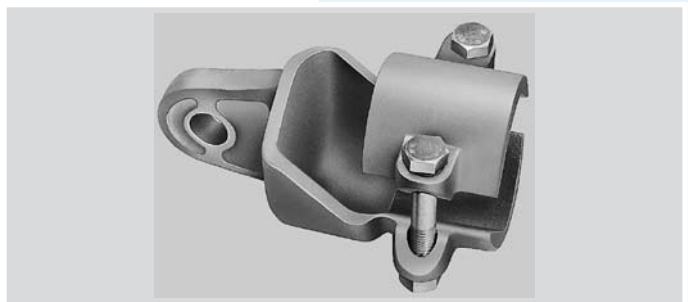

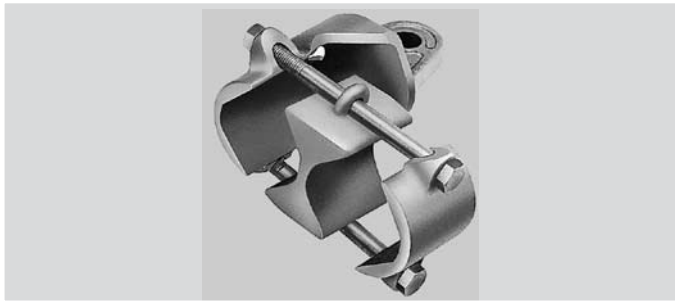

Tube end fitting with eye for two tubes

Order no. 521.152.1

Application: Connecting piece for 2 GRP rods/tubes with \varnothing 55 or 70 mm

Technical parameters: Material: copper alloy
 $F_{SMDL} = 5$ kN
 referred to the start of slipping of a GRP rod with $d = 55$ mm



Hook clip

Order no. 523.350.1

Application: Connecting piece for bridle-and-pulley suspension or fixing rope to GRP rod/tube with \varnothing 55 or 70 mm

Technical parameters: Material: copper alloy
 $F_{SMDL} = 2.5$ kN
 Suitable for thimbles up to a rating of 50

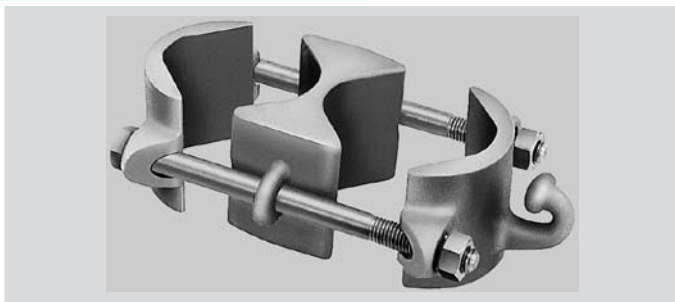

Twin-tube hook clip

Order no. 523.351.1

Application: Clamp for bridle-and-pulley suspension or fixing rope for 2 GRP rods/tubes with \varnothing 55 or 70 mm

Technical parameters: Material: copper alloy
 $F_{SMDL} = 2.5$ kN
 Suitable for thimbles up to a rating of 50

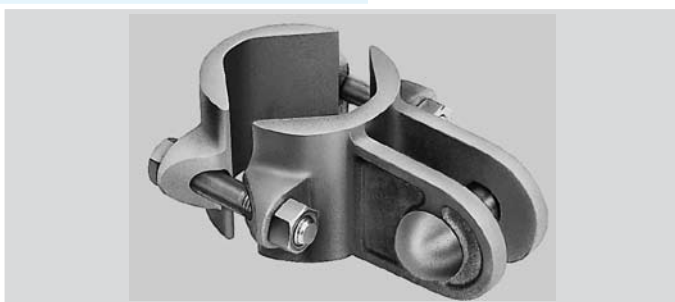

Clamp strap with clevis

Order no. 523.151.1

Application: Clamp for fastening registration tube and diagonal tube and for fixing all other ropes

Technical parameters: Material: copper alloy
 $F_{SMDL} = 2.5$ kN

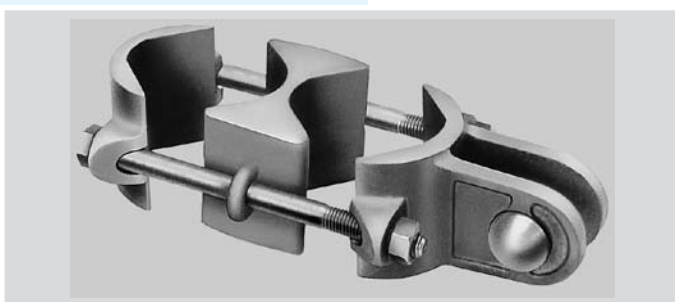

Twin-tube clevis clip

Order no. 523.152.1

Application: Clamp for fastening registration tube and diagonal tube and for fixing all other ropes, for 2 GRP rods/tubes with \varnothing 55 or 70 mm

Technical parameters: Material: copper alloy
 $F_{SMDL} = 2.5$ kN

Twin-tube clip

Order no. 523.851.1

Application: Clamp for connecting two GRP rods/tubes with \varnothing 55 or 70 mm

Technical parameters: Material: copper alloy

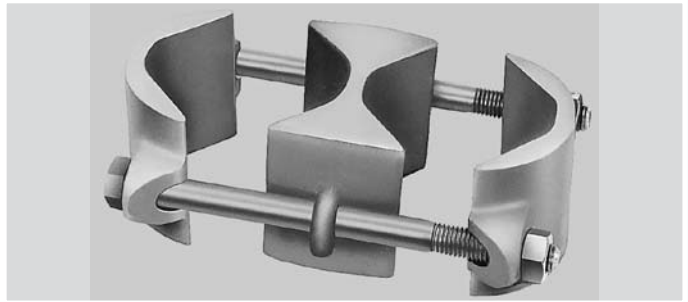

Pull-off fitting

Order no. 523.451.1

Application: Suspension for steady arm on cantilever tube with \varnothing 55 or 70 mm

Technical parameters: Material: copper alloy
 $F_{SMDL} = 5 \text{ kN}$

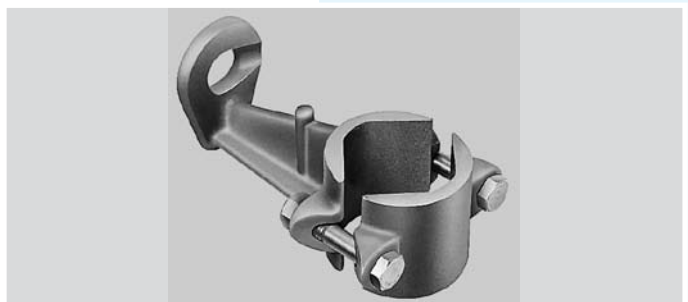

Twin-tube pull-off fitting

Order no. 523.452.1

Application: Suspension for steady arm on cantilever tube with \varnothing 55 or 70 mm, for 2 GRP rods/tubes

Technical parameters: Material: copper alloy
 $F_{SMDL} = 5 \text{ kN}$

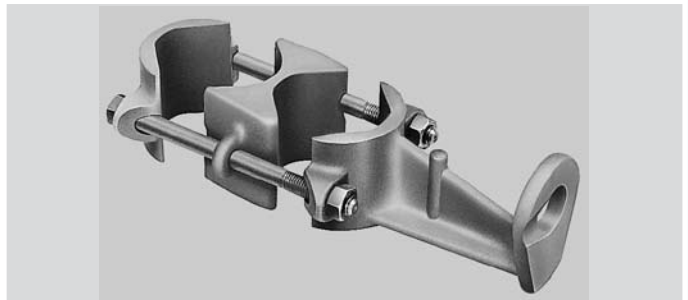

GRP rod

Order no. 525 211 1.203

Application: GRP rod for steady arm and section insulator suspension

Technical parameters: Material: GRP, UV-resistant
Color: RAL 7035, \varnothing d = 26 mm
Length: up to 6 m
 $F_{SMDL} = 59 \text{ kN}$

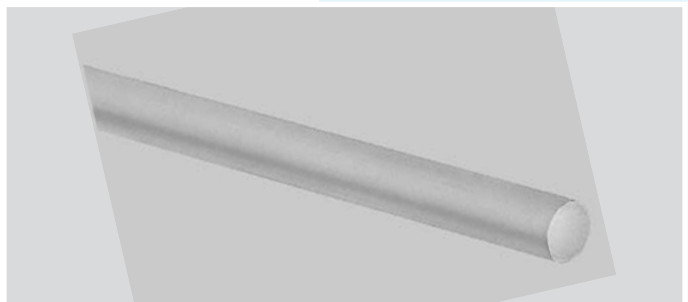

Loop insulator

Order no. 583.902.1

Application: All-purpose insulating element for tension

Technical parameters: Material: connecting fittings copper alloy
Insulation GRP, UV-resistant
 $F_{SMDL} = 20 \text{ kN}$
Suitable for 1.5 kV DC and 1 kV AC

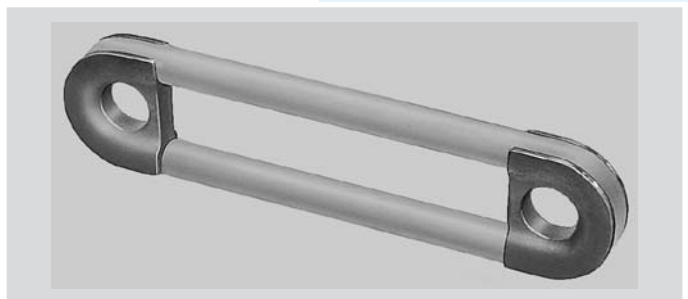

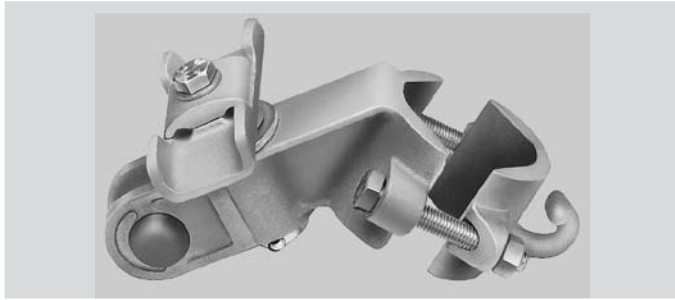

Catenary wire support clamp 50/70

Order no. 521.153.1

Application: Catenary wire support clamp for cantilever with 1 GRP rod/tube with \varnothing 55 or 70 mm

Technical parameters: Material: copper alloy
for messenger wire 50 mm² and 70 mm²
 $F_{SMDL} = 6$ kN

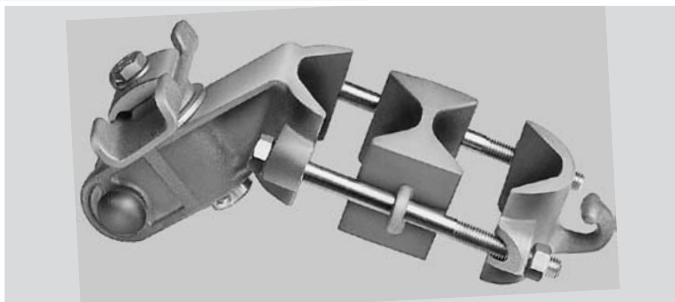

Catenary wire support clamp 50/70 for two tubes

Order no. 521.154.1

Application: Catenary wire support clamp with 2 GRP rods/tubes with \varnothing 55 or 70 mm

Technical parameters: Material: copper alloy
for messenger wire 50 mm² and 70 mm²
 $F_{SMDL} = 6$ kN

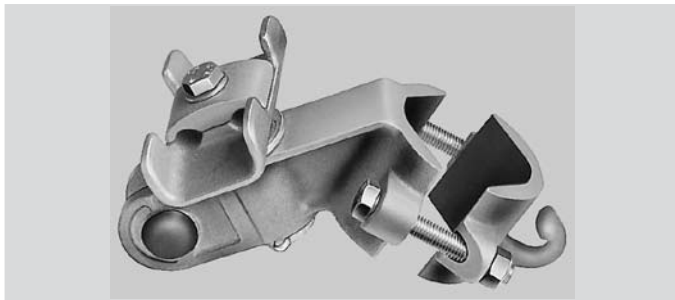

Catenary wire support clamp 95-150

Order no. 523.155.1

Application: Catenary wire support clamp for cantilever with 1 rod/tube with \varnothing 55 or 70 mm

Technical parameters: Material: copper alloy
for messenger wire 95 mm² to 150 mm²
 $F_{SMDL} = 6$ kN

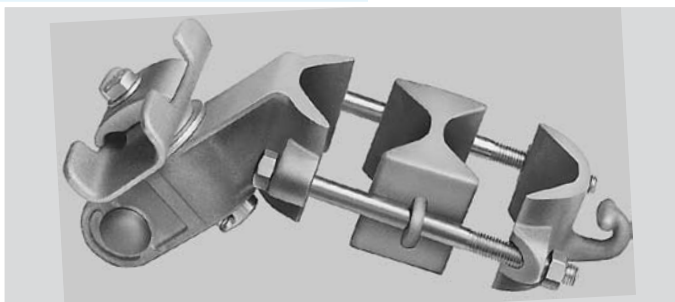

Catenary wire support clamp 95-150 for two tubes

Order no. 523.156.1

Application: Catenary wire support clamp for cantilever with 2 GRP rods/tubes with \varnothing 55 or 70 mm

Technical parameters: Material: copper alloy
for messenger wire 95 mm² to 150 mm²
 $F_{SMDL} = 6$ kN

Section insulator

A section insulator for the wide range of local transport applications has been developed from previous models and is available in two variants with different sizes and versions and a variety of suspension options to meet all requirements. The outstanding features of this insulator are its simple adjustment, easy installation and long life.

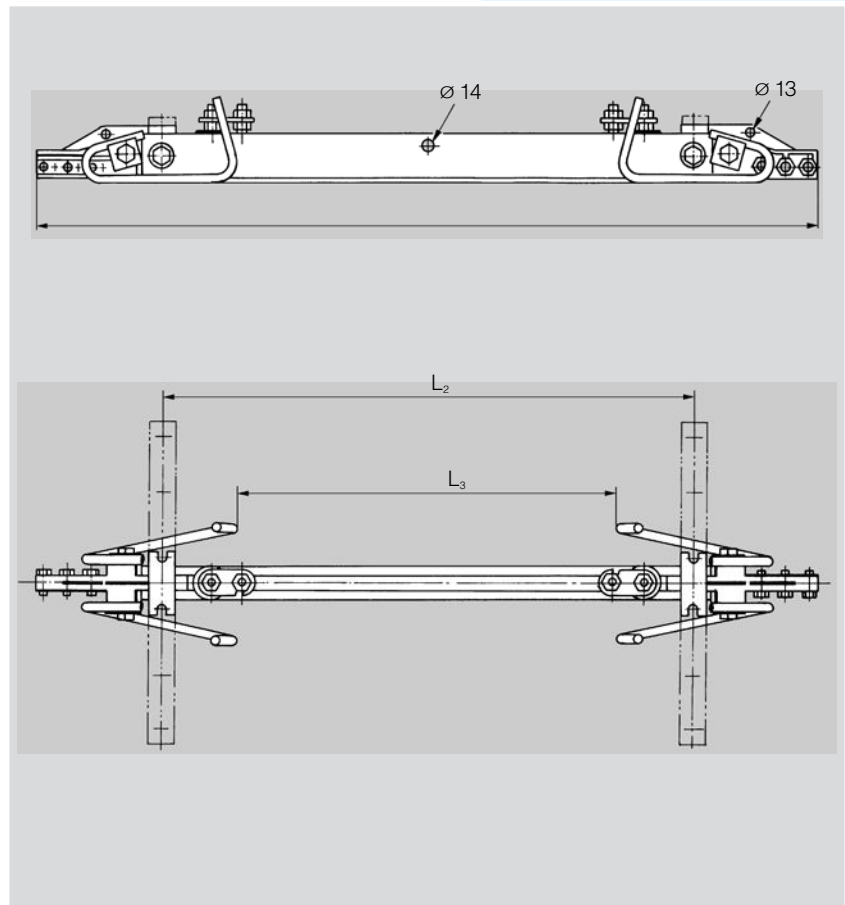

Figure 7 Section insulator with insulating skid

Type description		Type	Mass (kg)	L ₁ (mm)	L ₂ (mm)	L ₃ (mm)
Neutral section zone with	Suspension on insulating straps	a	7.20	1030	700	500
	with one insulating traverse	b	7.55	1030	700	500
	with two insulating traverses	c	7.90	1030	700	500
Neutral section zone without	Suspension on dead end clamps	d	6.20	680	350	150
	with one insulating traverse	e	6.55	680	350	150
	with two insulating traverses	f	6.90	680	350	150

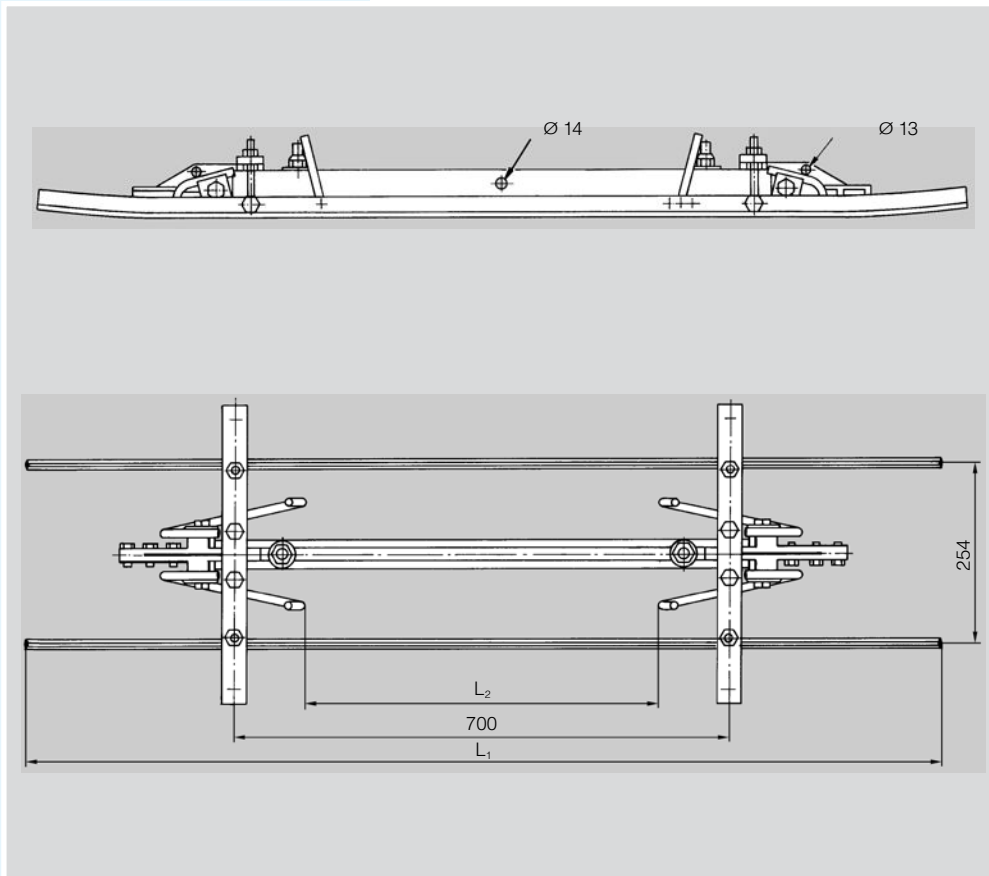

Figure 8 Section insulator with Cu sliding skids, with basic and improved insulation

Type description	Type	Mass (kg)	L ₁ (mm)	L ₂ (mm)
with basic insulation and short Cu sliding skids	a	13.00	1300	500
with improved insulation and short Cu sliding skids	b	13.60	1300	500
with basic insulation and long Cu sliding skids	c	13.85	1500	500
with improved insulation and long Cu sliding skids	d	14.45	1500	500

Figure 9

Section insulator with insulating skid

Type c

The arcing horns, the insulating skid of high-strength plastic material moved by the pantograph, the copper skids and the suspensions can be aligned and adjusted separately, which means the section insulator can be very easily adapted to different installation requirements. All parts are fitted with self-locking nuts.

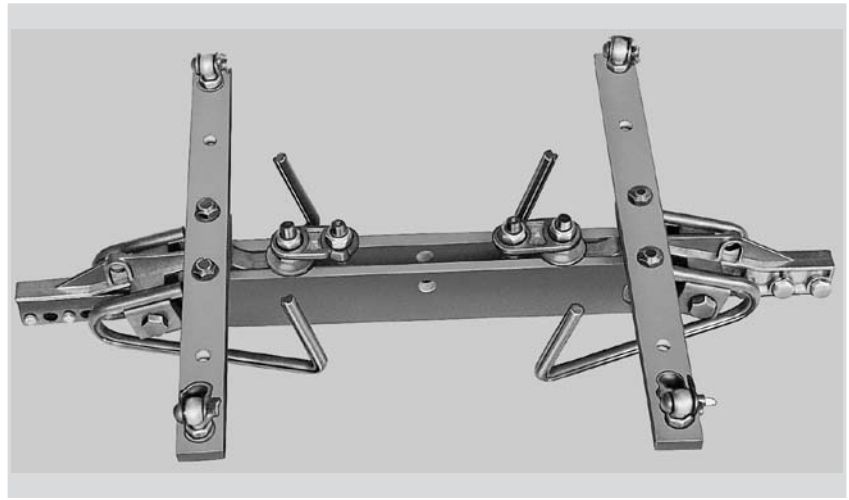
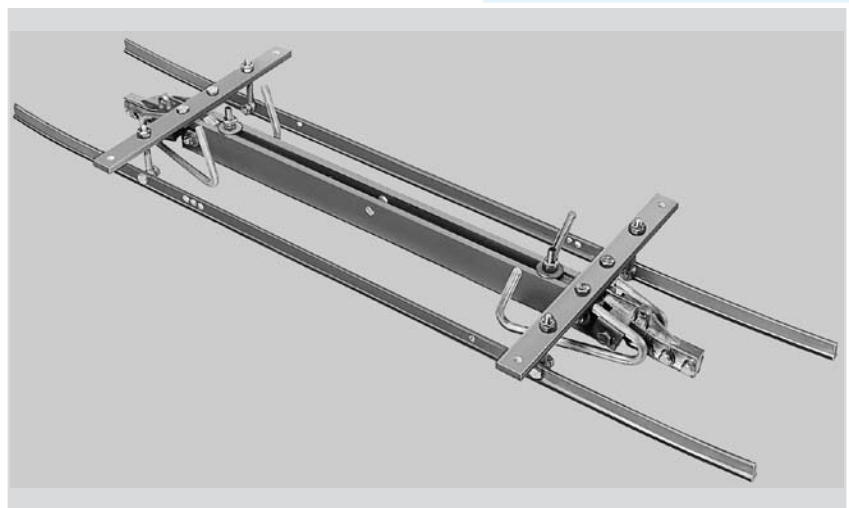

Figure 10

Section insulator with Cu sliding skids

Type d

The section insulator is particularly easy to install, as it can be placed ready for use on the uncut contact wire and fixed. The contact wire of the insulation distance is then cut out between the fixing clamps. The tensile force is borne by the two plastic insulating straps. The copper skids can also be connected to a voltage on one side or used as a switching element.



The section insulators can also be supplied in different sizes on request.

Selection of complete components and component assemblies

The figures below show various sub-assemblies and component combinations and the variety of solutions possible with the small number of components.

Our component range opens up new and broad horizons for the construction of local transport catenary systems.

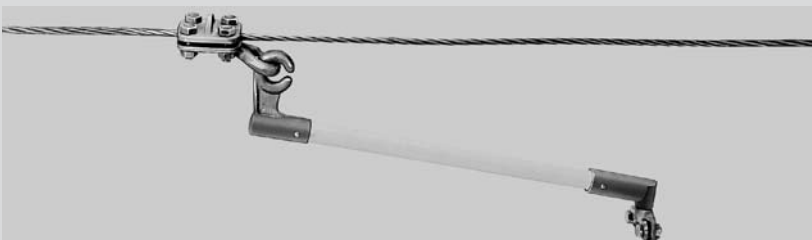
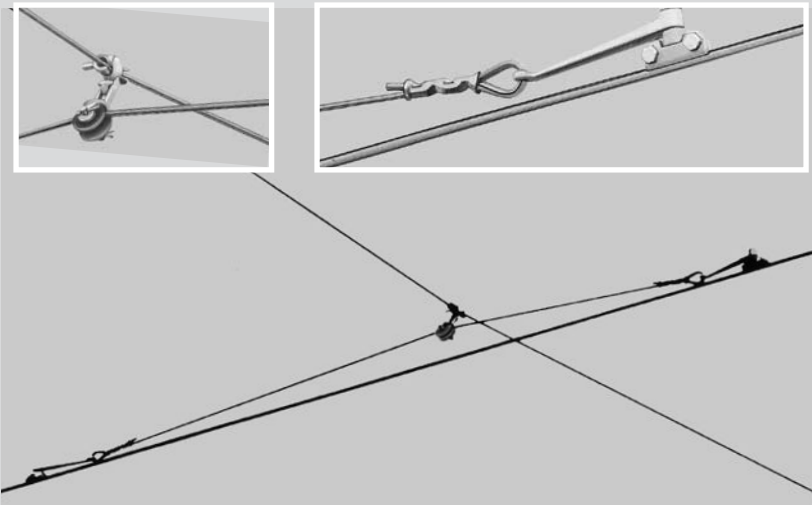
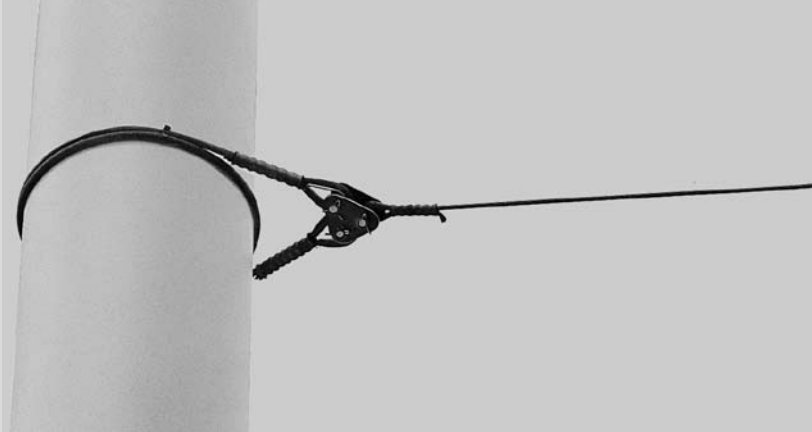

Figure 11 Pole cable loop
Rope Bz 35 or Bz 50

Figure 12 Bridle-and-pulley suspension with Minoroc rope
Ø 9 mm

Figure 13 GRP steady arm
angled 180°, with ring clamp

Figure 14 Curve pull-off
double, on cantilever, for 1 contact wire

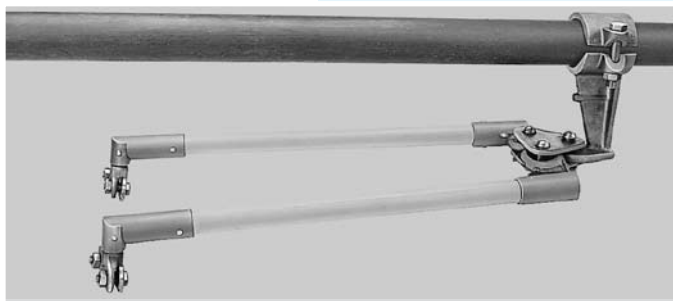

Figure 15 Swivel bracket and hinge for cantilever
with tube end fitting

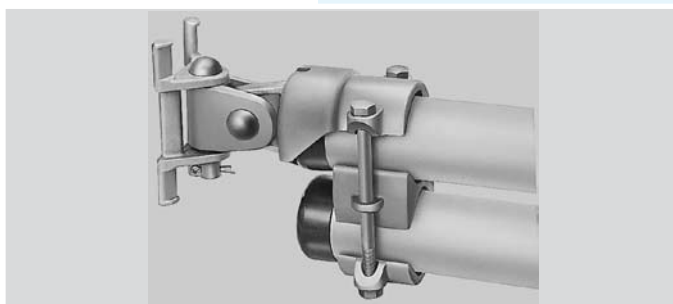

Figure 16 Double clevis clip

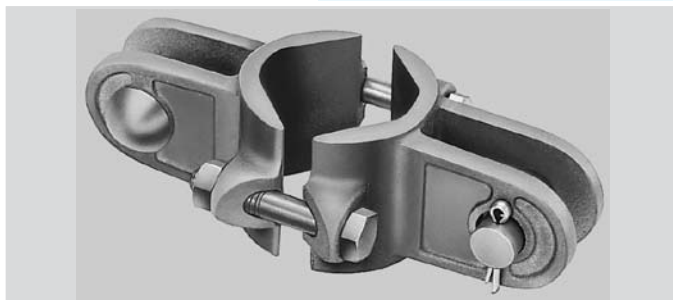

Figure 17 Combination of clamp strap with clevis and hook clip

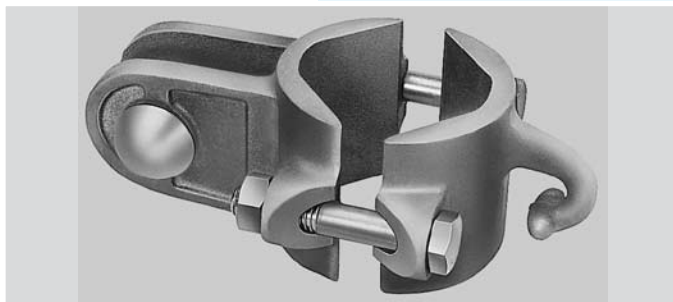
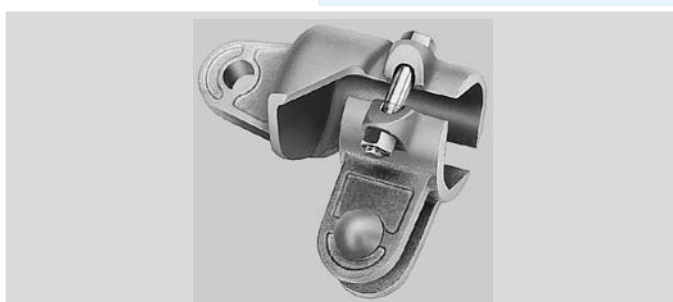

Figure 18 Combination of tube end fitting with eye and hook clip



RIBEF[®]
MADE TO **fit**

Richard Bergner Elektroarmaturen GmbH & Co. KG
Bahnhofstr. 8-16 · 91126 Schwabach · Germany · Telephone +49 91 22/87-0 · Fax +49 91 22/87-1506
E-mail elektroarmaturen@ribe.de / ev@ribe.de · Internet www.ribe.de