

Independent, accredited testing station · Member laboratory of STL and LOVAG

TEST REPORT

NO. 1666.0301.2.281

3M Laboratories (Europe) Branch office of 3M Deutschland GmbH Carl-Schurz-Straße 1 D-41453 Neuss	CLIENT
---	---------------

3M Laboratories (Europe) Branch office of 3M Deutschland GmbH	MANUFACTURER
--	---------------------

Short-circuit-proof bundles of three single-core power cables (with extruded plastic insulation) with glass-fibre reinforced polyester tape	TEST OBJECT
---	--------------------

Scotch 45 bk	TYPE
--------------	-------------

Test sample	MANUFACTURING NO.
-------------	--------------------------

Width	19 mm	RATED CHARACTERISTICS GIVEN BY THE CLIENT
Thickness	0.2 mm	
Tearing strength per 10 mm	700 N	
Elongation at break	3 %	
Rated voltage U_0/U	6/10 kV	
Maximum value of highest system voltage U_m	12 kV	
Rated cross-section range	150 mm ²	

On the basis of CENELEC Harmonization Document HD 629.1 S1 November 1996 CENELEC Harmonization Document HD 628 S1 November 1996 DIN VDE 0278-629.1 (VDE 0278 Teil 629-1): 1997-11 DIN VDE 278-628 (VDE 278 Teil 628): 1997-11	NORMATIVE DOCUMENT
---	---------------------------

Tests on the basis of test series C1	TEST PERFORMED
--------------------------------------	-----------------------

14 May, 15 May and 23 May 2002	DATE OF TEST
--------------------------------	---------------------

See Sub-clause 4.7.	TEST RESULT
---------------------	--------------------



PROF. DR. JÜRGEN PANNICKE
Managing Director
Berlin, 29 August 2002

RONALD BORCHERT
Test engineer in charge



Independent test laboratory, accredited by Deutsche Akkreditierungsstelle Technik (DATech) e.V. in the fields of h.v. apparatus and switchgear, power cables and power cable accessories, lv. apparatus and switchgear, installation equipment and switching and control equipment



DAT - P - 019/92

Contents	Sheet
1. Present at the test.....	3
2. Test performed.....	3
3. Identity of the test object.....	4
3.1 Technical data and characteristics.....	4
3.2 Identity documents.....	4
4. Test series C1.....	5
4.1 Test laboratory.....	5
4.2 Normative document.....	5
4.3 Required test parameters.....	6
4.4 Test arrangement.....	7
4.4.1 DC voltage dry withstand test (test 1).....	7
4.4.2 AC voltage dry withstand test (tests 2 and 5).....	7
4.4.3 Dynamic short-circuit test of the conductor (test 3).....	7
4.4.4 Impulse voltage test at ambient temperature (test 4).....	7
4.5 Test and measuring circuits.....	8
4.5.1 DC voltage dry withstand test (test 1).....	8
4.5.2 AC voltage dry withstand test (tests 2 and 5).....	9
4.5.3 Dynamic short-circuit test of the conductor (test 3).....	10
4.5.4 Impulse voltage test at ambient temperature (test 4).....	11
4.6 Test results.....	12
4.6.1 DC voltage dry withstand test (test 1).....	12
4.6.2 AC voltage dry withstand test (test 2).....	13
4.6.3 Dynamic short-circuit test of the conductor (test 3).....	14
4.6.4 Impulse voltage test at ambient temperature (test 4).....	15
4.6.5 AC voltage dry withstand test (test 5).....	16
4.7 Assessment of the test results on the basis of test series C1.....	17
5. Appendices.....	18
5.1 Photos.....	18
5.2 Oscillograms.....	20
5.3 Drawings.....	21
5.4 Identification of test cable.....	22

This test document consists of 22 sheets.

Distribution

Copy No.: 3

Copies Nos. 1 and 2 in German:

3M Laboratories (Europe)
Branch office of 3M Deutschland GmbH

Copies Nos. 3 and 4 in English:

3M Laboratories (Europe)
Branch office of 3M Deutschland GmbH

1. Present at the test

Mr. Borchert, Ronald IPH test engineer in charge
 Mr. Wittwer IPH test engineer (dielectric tests)

Mr. Weichold 3M Europe (partially present)

2. Test performed

All tests of test series C1 in the following order:

Sequence	Test	Type of test
C1 ¹⁾	1	DC voltage dry withstand test
	2	AC voltage dry withstand test
	3	Dynamic short-circuit test of the conductor
	4	Impulse voltage test at ambient temperature
	5	AC voltage dry withstand test

Note: ¹⁾ on the basis of

3. Identity of the test object

3.1 Technical data and characteristics

The technical data and characteristics of the test object are defined by the following parameters and specified by the client

Test object:	Short-circuit-proof bundles of three single-core power cables (with extruded plastic insulation) with glass-fibre reinforced polyester tape		
Type:	Scotch 45 bk		
Manufacturer:	3 M Deutschland GmbH		
Serial No.:	Test sample		
Year of manufacture:	2002		
Rated characteristics:	Rated voltage U_0/U	6/10 kV	
	Maximum value of highest system voltage U_m	12 kV	
	Rated cross-section range	150 mm ²	
Design:	Wrapping at a distance of	200 mm	
	Number of layers	10	
	Tape width	19 mm	
	Tape thickness	0.2 mm	
	Tearing strength per 10 mm	700 N	
	Elongation at break	3 %	
	Cable	Single-core cable with extruded plastic insulation, screened	
	Cable marking	NA2XS2Y 1x150 RM/25 6/10 kV	
	Designation of manufacturer	Nexans	
	Material of conductor	Al	
	Material screen	Cu	

3.2 Identity documents

The manufacturer confirms that the test object has been manufactured in compliance with the drawings given in this document. IPH did not verify this compliance in detail.

The identity of the test object is fixed by the following drawings and data submitted by the client:

Name of drawing	Drawing No.	Date of drawing	Author	Notes
Datenblatt Scotch 45 bk	EP-399	-	3 M Elektro Produkte	Sheet 21

Entry of test objects at IPH: 13 May 2002

4. Test series C1

4.1 Test laboratory

High-voltage test laboratory, high-voltage hall 2 and
Low-voltage test laboratory, test room 2

4.2 Normative document

On the basis of
CENELEC Harmonization Document HD 629.1 S1 November 1996
CENELEC Harmonization Document HD 628 S1 November 1996
DIN VDE 0278-629.1 (VDE 0278 Teil 629-1): 1997-11
DIN VDE 278-628 (VDE 278 Teil 628): 1997-11

4.3 Required test parameters

Test No.	Type of test	Required test parameters	
1	DC voltage dry withstand test	Test voltage $6 \times U_0$: Duration of test: Polarity:	36 kV 15 min Negative
2	AC voltage dry withstand test	Test voltage $4.5 \times U_0$: Test frequency: Duration of test:	27 kV 50 Hz 5 min
3	Dynamic short-circuit test of the conductor	Peak short-circuit current: Duration of short-circuit: Number of short-circuits:	125 kA min. 20 ms 1
4	Impulse voltage test at Ambient temperature	Front time: Virtual time to half value: Test voltage: Number of impulses: Polarity: Conductor temperature:	1.2 μ s 50 μ s 75 kV 10 impulses pos./neg. ϑ_U
5	AC voltage dry withstand test	Test voltage $2.5 \times U_0$: Test frequency: Duration of test:	15 kV 50 Hz 15 min

4.4 Test arrangement

Test arrangement to CENELEC Harmonization Document HD 628 S1 November 1996, Clause 12. To apply the test voltage, the three single-core power cables under test of about 3-m length had been equipped by the client on both sides by auxiliary indoor sealing ends of QT2 92-EB62-2 type. All test voltages were applied to the core against the cable screen, which was connected to the test earth.

4.4.1 DC voltage dry withstand test (test 1)

Test arrangement to CENELEC Harmonization Document HD 628 S1 November 1996, Clause 5

4.4.2 AC voltage dry withstand test (tests 2 and 5)

Test arrangement to CENELEC Harmonization Document HD 628 S1 November 1996, Clause 4

4.4.3 Dynamic short-circuit test of the conductor (test 3)

Test arrangement to CENELEC Harmonization Document HD 628 S1 November 1996, Clause 11

The prefabricated cable pieces were bundled up by glass-fibre reinforced polyester tape (test object) on 10 points at 200-mm intervals. Each of the bundles consisted of 10 layers of tape. For the dynamic short-circuit test, the conductors of test lines 1 and 2 were connected on one end to a short-circuit bridge and on the other end two-pole with the short-circuit current source. The two-pole test was selected in order to reach maximum power stress. However, the third test line was included in the bundle.

4.4.4 Impulse voltage test at ambient temperature (test 4)

Test arrangement to CENELEC Harmonization Document HD 628 S1 November 1996, Clause 6

4.5 Test and measuring circuits

4.5.1 DC voltage dry withstand test (test 1)

Technical data of test circuit

DC voltage source

Test transformer:	Rated voltage	100	kV
	Rated power	8	kVA
	Rated frequency	50	Hz
Rectifier:	Rated voltage	135	kV
	Rated current	15	mA
Smoothing capacitor:	Capacitance	10	nF

Technical data of measuring circuit

Measuring point	Measured quantity	Measuring sensor/device	Technical parameters
1	Test voltage	Ohmic divider with MU11 peak voltmeter	Ratio 560

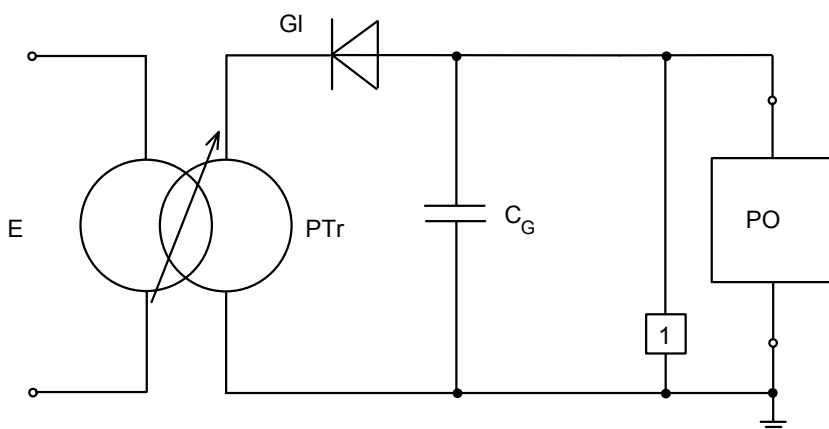

- E Supply
- PTr Test transformer with variable transformer connected in series
- GI Rectifier
- C_G Smoothing capacitor
- 1 Measuring point
- PO Test object

Figure 1: Test and measuring circuit for the DC voltage dry withstand test

Test and measuring circuits (continued)

4.5.2 AC voltage dry withstand test (tests 2 and 5)

Technical data of test circuit

Single-phase AC voltage source

Test transformer:	Rated voltage	125	kV
	Rated power	100	kVA
	Rated frequency	50	Hz
	Damping resistance	0.67	kOhm

Technical data of measuring circuit

Measuring point	Measured quantity	Measuring sensor/device	Technical parameters
1	Test voltage	Capacitive divider with MU11 peak voltmeter	Ratio 865

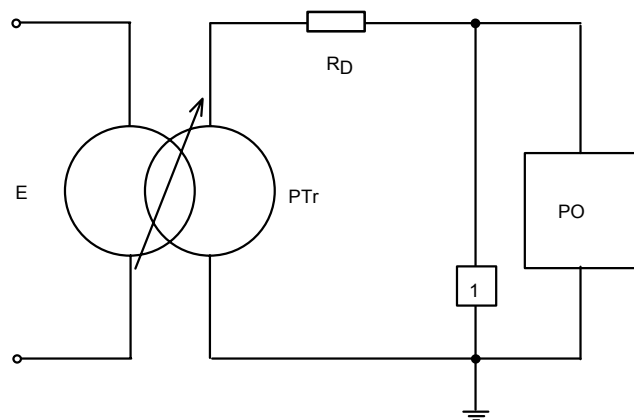

- E Supply
- PTr Test transformer with variable transformer connected in series
- R_D Damping resistance
- 1 Measuring point
- PO Test object

Figure 2: Test and measuring circuit for the AC voltage dry withstand test

Test and measuring circuits (continued)

4.5.3 Dynamic short-circuit test of the conductor (test 3)

Technical data of measuring circuits

Test No.	Meas. point / channel	Measured quantity	Measuring sensor	Technical parameters
202 0642	1	Current test objects 1 and 2	Coaxial shunt	20.08 kA/V
	2	Test voltage	Voltage transformer	

Transmission device: Groß optoelectronic isolating amplifier

Recording instruments: Krenz PSO 7030 transient recorder

Evaluation: MEVA 2.05

Test circuit

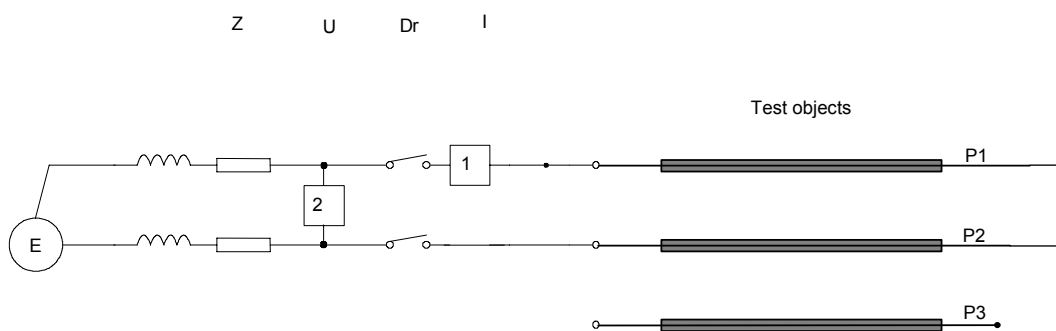

- E Supply
- Dr Making switch
- Z Test circuit impedance
- U Test voltage measurement
- I Current measurement
- 1 - 2 Measuring points

Figure 3: Test and measuring circuits for the short-circuit test

Test and measuring circuits (continued)

4.5.4 Impulse voltage test at ambient temperature (test 4)

Technical data of test circuit

Impulse circuit:	Number of stages	n =	4
	Impulse capacitance	$C_S =$	35 nF
	Loading capacitance	$C_B =$	1.5 nF
	Damping resistance	$R_D =$	2440 Ω
	Discharge resistance	$R_E =$	2200 Ω

Technical data of measuring circuit

Measuring point	Measured quantity	Measuring sensor/device	Technical parameters
1	Test voltage	R divider of SMR 10/770 type (TuRD) with digital measuring instrument of DMI 551 type (Haefely) and TDS 220 digital oscilloscope (Tektronix)	Ratio 472

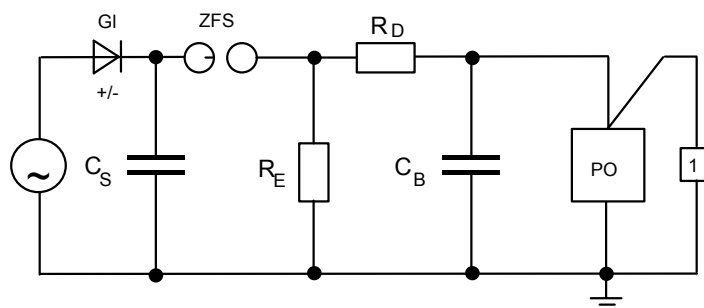

- GI Rectifier
- C_S Impulse capacitance
- ZFS Spark gap
- R_E Discharge resistance
- R_D Damping resistance
- C_B Loading capacitance
- PO Test object
- 1 Measuring point

Figure 4: Test and measuring circuit for the impulse voltage test

4.6 Test results

4.6.1 DC voltage dry withstand test (test 1)

Polarity: Negative

Duration of test after having reached full voltage: 15 min

Test temperature: Ambient temperature 20 °C

Conductor temperature 20 °C

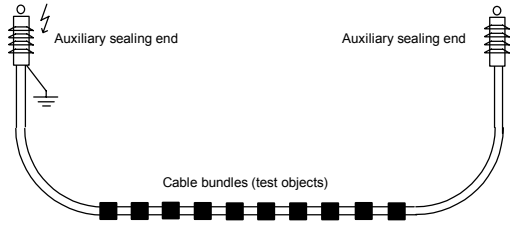
Test arrangement			Test voltage	Result
No. of test object	Voltage applied to	Earthed		
			kV	
1	Conductor	Screen	-36	No disruptive discharge
2	Conductor	Screen	-36	No disruptive discharge
3	Conductor	Screen	-36	No disruptive discharge

Notes: -

Test results (continued)

4.6.2 AC voltage dry withstand test (test 2)

Duration of test after having reached full voltage: 5 min

Test frequency: 50 Hz

Test temperature: Ambient temperature 20 °C

Conductor temperature 20 °C

Test arrangement			Test voltage	Result
No. of test object	Voltage applied to	Earthed		
			kV	
1	Conductor	Screen	27	No disruptive discharge
2	Conductor	Screen	27	No disruptive discharge
3	Conductor	Screen	27	No disruptive discharge

Notes: -

Test results (continued)

4.6.3 Dynamic short-circuit test of the conductor (test 3)

Condition of test object before test: Prestressed
 Ambient temperature: 20 °C
 Conductor temperature: 20 °C

Test parameters:

Test No.		202 0642
Peak current	kA	126
Symmetrical short-circuit current	kA	-
Duration of short-circuit	ms	20.4
i^2t	$10^6 A^2s$	103
Symmetrical short-circuit current 1 s	kA	-
Test line No.		1, 2
Notes		o.k.

Notes:

o.k.: The test object (bundle) is able to carry the peak current.

Condition of test object after test:

No external damage is visible on the cable bundles.

Test results (continued)

4.6.4 Impulse voltage test at ambient temperature (test 4)

Full wave: Front time $T_1 = 1.27 \mu s$
 Virtual time to half value $T_2 = 54.5 \mu s$

Test temperature: Ambient temperature $20 \text{ }^\circ\text{C}$
 Conductor temperature $20 \text{ }^\circ\text{C}$

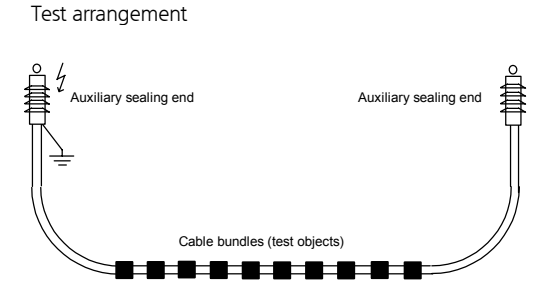
Test arrangement			Test voltage	Result
				
No. of test object	Voltage applied to	Earthed	kV	No. of impulses/disruptive discharges
1	Conductor	Screen	+75 -75	10/0 10/0
2	Conductor	Screen	+75 -75	10/0 10/0
3	Conductor	Screen	+75 -75	10/0 10/0

Notes: -

Test results (continued)

4.6.5 AC voltage dry withstand test (test 5)

Duration of test after having reached full voltage: 15 min

Test frequency: 50 Hz

Test temperature: Ambient temperature 20 °C

Conductor temperature 20 °C

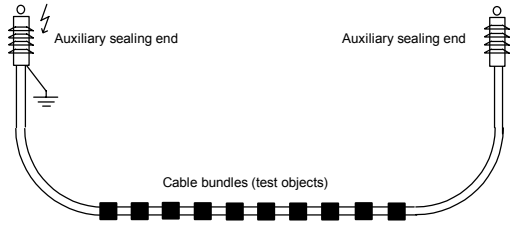
Test arrangement			Test voltage	Result
No. of test object	Voltage applied to	Earthed		
			kV	
1	Conductor	Screen	15	No disruptive discharge
2	Conductor	Screen	15	No disruptive discharge
3	Conductor	Screen	15	No disruptive discharge

Notes: -

4.7 Assessment of the test results on the basis of test series C1

- Test 1

In the DC withstand voltage test at -36 kV/15 min, no disruptive discharge occurred on any of the three test objects.

- Test 2

In the 50-Hz AC voltage dry withstand test at 27 kV/5 min, no disruptive discharge occurred on any of the three test objects.

- Test 3

In the "dynamic short-circuit test of the conductor" with a peak current of 125 kA, no visible damage was detected.

- Test 4

In the impulse voltage test at ambient temperature with 10 test impulses of 75-kV lightning impulse voltage 1.2/50 of each polarity, no disruptive discharge occurred on any of the three test objects.

- Test 5

In the 50-Hz AC voltage dry withstand test at 15 kV/15 min, no disruptive discharge occurred on any of the three test objects.

In the performed tests, all three of the test objects have met the requirements defined by CENELEC Harmonization Document HD 629.1 S1 November 1996.

5. Appendices

5.1 Photos



Figure 5: View of test objects before the dynamic short-circuit test



Figure 6: View of test objects after the dynamic short-circuit test

5.2 Oscillograms

Osz.-Nr. 2020642
Osc.-No.

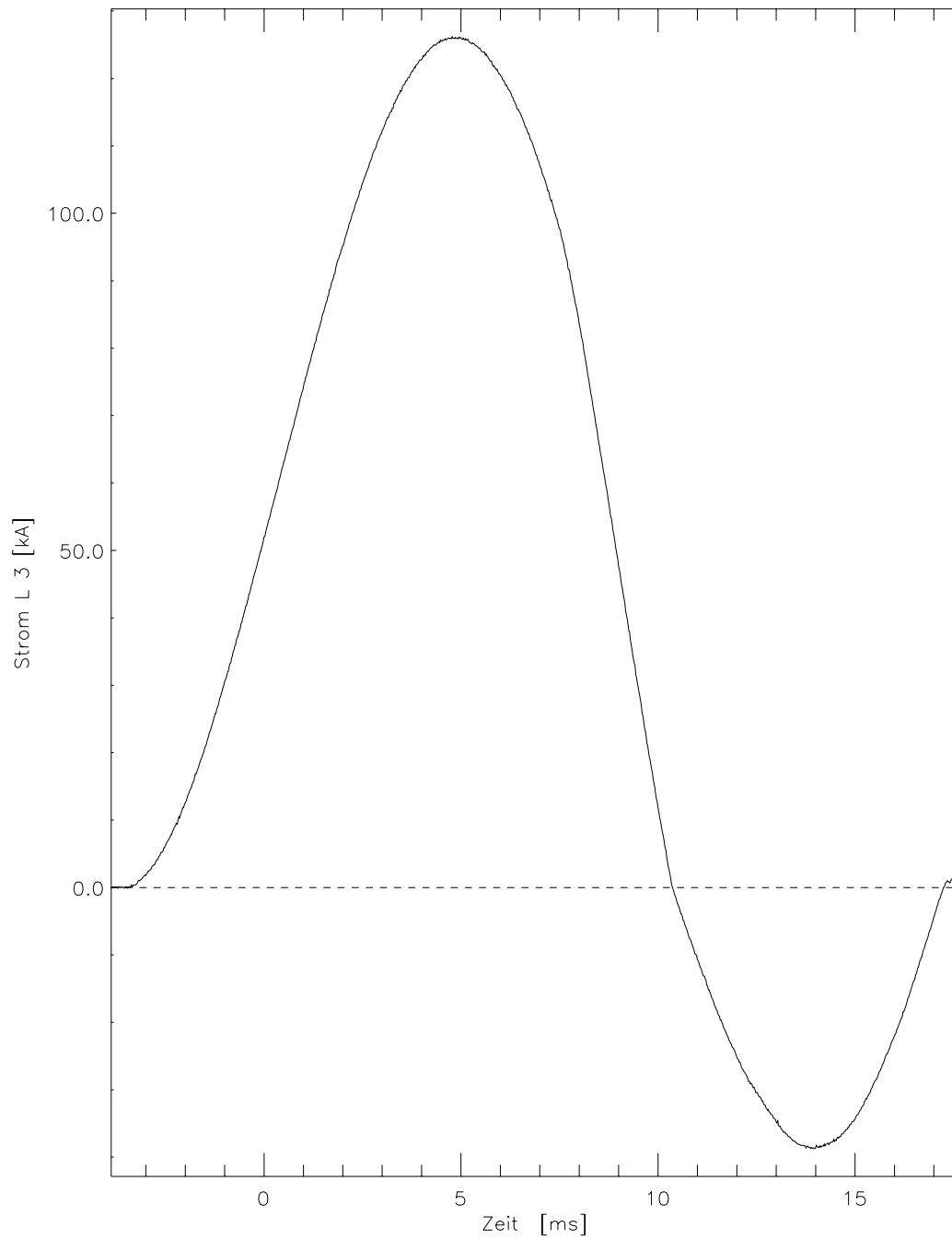

5.3 Drawings

Scotch™ 45 bk

Glasfaserverstärktes Polyesterband

Produktbeschreibung

Das 3M Elektro-Isolierband Nr. 45bk besteht aus einer schwarz kaschierten Polyesterfolie als Trägermaterial mit einem glasfaserverstärkten Kautschukklebstoff. Es zeichnet sich aus durch eine sehr hohe Reißfestigkeit, eine hohe Durchschlagsfestigkeit und seine UV-Beständigkeit.

Anwendungsbereich

- Abbinden von Drahtbündeln
- besonders geeignet für alle Arten von hoch beanspruchten Befestigungen
- kurzschlussstromfeste Bündelung von Mittelspannungskabeln
- durch die schwarze Abdeckung speziell für Anwendung in Freiluft

Technische Information

Farbe	schwarz
Dicke	0,20 mm
Reißkraft	700 N/10mm
Reißdehnung	3 %
Klebevermögen (Abzichkraft von der Platte)	5 N/10mm
spezieller Durchgangswiderstand	$10^{11} \Omega \text{ cm}$
Durchschlagsspannung	5 kV
Elektrolyt. Korrosionswirkung	A 1,4
Isolierstoffklasse	B (105°C)

Alle Werte verstehen sich als Durchschnittswerte

Abmessungen

Typ	Abmessung
Scotch™ 45 bk	19 mm x 20 m



Das IPH hat die Übereinstimmung
hierin in allen Einzelheiten überprüft

Das geprüfte Gerät entspricht
unserer Zeichnung.

Auftraggeber:
Unterschrift:

[Handwritten signature]
[Handwritten signature]

3M Deutschland GmbH
Elektro-Produkte
Carl-Schutz-Str. 1
41453 Neuss
Tel: 02131 / 14-3574
Fax: 02131 / 14-3200

3M Elektro Produkte

EP-359
10/01

5.4 Identification of test cable

To CENELEC Harmonization Document 629.1 S1: 1996 Annex A
for cable with plastic insulation

Rated voltage $U_0/U (U_m)$ 6/10 (12) kV

Cable construction	<input checked="" type="checkbox"/> 1-core	<input checked="" type="checkbox"/> screened	
	<input type="checkbox"/> 3-core	<input type="checkbox"/> individually screened	
	<input type="checkbox"/> 4-core	<input type="checkbox"/> not individually screened	
Conductors	<input checked="" type="checkbox"/> Al	<input type="checkbox"/> Cu	
	<input checked="" type="checkbox"/> stranded	<input type="checkbox"/> solid	
	<input checked="" type="checkbox"/> round	<input type="checkbox"/> shaped	
	<input type="checkbox"/> 120 mm ²	<input checked="" type="checkbox"/> 150 mm ²	<input type="checkbox"/> 185 mm ²
	<input type="checkbox"/> other cross-section	mm ²	
	<input type="checkbox"/> cross-section branch	mm ²	
Cable insulation	<input type="checkbox"/> PVC	<input checked="" type="checkbox"/> XLPE	
	<input type="checkbox"/> EPR	<input type="checkbox"/> HEPR	
Insulation screen	<input checked="" type="checkbox"/> bonded	<input type="checkbox"/> strippable	
	<input checked="" type="checkbox"/> wires	<input type="checkbox"/> tapes	<input type="checkbox"/> None
oversheath	<input type="checkbox"/> PVC	<input checked="" type="checkbox"/> PE (state type)	<input type="checkbox"/> other material
Water blocking (if any, where?)	<input type="checkbox"/> in conductor	<input type="checkbox"/> under oversheath	<input type="checkbox"/> other place
Diameter	• Conductor	14.2 mm	
	• conductor screen	14.8 mm	
	• Insulation	21.8 mm	
	• insulation screen	23.3 mm	
	• oversheath	30.7 mm	

Cable marking NA2XS2Y 1 x 150 RM/25 6/10 kV
made by Nexans